

Please read this manual before operating the equipment

The equipment contained in this box should only be used by trained personnel wearing appropriate personal protective equipment for the fluid contained.

2000ML - 5000ML – 1000CL
CT SERIES ELECTRICALLY AGITATED
Series Reservoirs
Operating Manual



**This manual contains
Important Warnings and Instructions**

Read and retain for future reference

Contents

Safety Warnings	3
Operating & Technical Data	8
Rules and Regulations for the use of pressure tanks	9
Functional Description	11
2000ML-CTEL Exploded View / Specifications	14
2000ML-CTEL Replacement Parts	15
5000ML-CTEL Exploded View / Specifications	16
5000ML-CTEL Replacement Parts	17
1000CL-CTEL Exploded View / Specifications	18
1000CL-CTEL Replacement Parts	19
Precautions of use	20
Conditions of Use	21
Instructions	23
Setup	39
Pressure Relief Procedure / Refiling / Wetted Parts List	53
Troubleshooting	54
Alarms and warnings	59
Maintenance & Cleaning	64
Drawings	67
Warranty	70
Declaration of Conformity	Back Cover

The ST-AG Series Reservoirs fall in the Pressure Equipment Directive 2014/68/EU Article 4, Clause 3 – Sound Engineering Practice and has been certified safe to use by SR-TEK.

Safety Warnings



Halogenated Hydrocarbon Fluid Hazard

NEVER USE halogenated hydrocarbon solvents or fluids containing such solvents in this equipment. Examples of halogenated hydrocarbon solvents are: trichloroethane, methylene chloride, fluids with the prefix “fluoro-“, “chloro-“, “bromo-“ or “iodo-“, etc.

These solvents can cause an explosion when used in a pressurised fluid pumping system. The resulting explosion may cause death, serious bodily injury or substantial property damage.

List of fluid recommended

The following is a non-exhaustive list of examples of fluids recommended with our reservoirs.

- Accelerators
- Activators
- Anaerobic
- Conformal coating
- Cyanoacrylate adhesives
- Electrolytes
- Epoxies
- Liquid fluxes
- Low viscosity greases
- Low viscosity silicones
- Inks
- Oils
- Optical dyes
- Lacquers and Optical lacquers
- Paints
- Primers
- Reagents
- Saline solutions
- UV adhesives and UV inks
- Water and Water based fluids
- White glue

We recommend placing the fluid bottle inside the tank or the use of a plastic liner.

For all other fluids, please refer to the manufacturer technical data sheet or contact us for compatibility check.

**If you have any questions,
please contact us for assistance.**

E-mail technical@sr-tek.com

Pressurized Equipment Hazard

High pressure fluid can cause serious injury. This equipment is for professional use only. Observe all warnings.

Read and understand all applicable instruction manuals before placing equipment into service.

Equipment Misuse Hazard

GENERAL SAFETY – Any use of the reservoir and related accessories not consistent with that described in this manual, such as modifying or removing parts, over pressurising, using incompatible fluids and chemicals, or using worn, damaged or incompatible parts can cause them to rupture resulting in serious bodily injury, including fluid splashed in the eyes or on the skin, or fire, explosion or other property damage.

 **NEVER** alter or modify any part of this equipment, as doing so may cause it to malfunction.

CHECK all reservoir components regularly and replace any worn or damaged parts with only SR-TEK supplied or approved parts. **BE SURE** that all connected equipment and accessories are rated to withstand the maximum operating pressure of the reservoir.

Personal Protective Equipment

Wear all protective eyewear, gloves, clothing and respirator as recommended by the manufacturer of the fluid used.

System Pressure

NEVER exceed the maximum reservoir pressure of 4bar gauge (60psi). The maximum supply pressure to the reservoir regulator must not exceed 10 bar gauge (150psi).

 **BE SURE** that all connected equipment and accessories are rated to withstand the maximum operating pressure of the reservoir.

If an Air filter regulator is not used, be certain your plant air is properly filtered and dry. Oil or particles in the air supply line can cause erratic performance and can contaminate the fluid contained, if not properly filtered.

i Fluid Compatibility

BE SURE that all fluids, including their vapours, contained in the reservoir are compatible with all materials on the wetted materials list on page 53 of this manual. Read the fluid manufacturer's literature, including the MSDS (Material Safety Data Sheet) and observe all warnings before pouring the fluid into the reservoir.

If in doubt, contact SR-TEK for chemical compatibility between your fluid and the wetted parts of the tank. It is the operator's responsibility to ensure safe installation and use of the product.

Serious injuries to people and equipment around may result from improper installation, use of the device, wrong operation, non-observance of the safety instructions, inappropriate removal of reservoir components, including lid, inappropriate repair or modifications to the product.

Fill Level

DO NOT over fill the reservoir. The recommended maximum fill level is 20 to 30mm below the reservoir top flange.

Tipping and Dropping Hazard

BE SURE that the reservoir is placed on a hard-levelled surface and that all tubing lengths are of sufficient length to allow free motion of all movable components attached to the reservoir.

DO NOT pull on tubing to move the reservoir.

Tipping the reservoir or otherwise supporting it on its side can cause fluid to enter both the pressure regulator and pressure relief valve, interfering with their normal function and risk of cracks to the clear tube. **A damaged pressure regulator and/or damaged pressure relief valve may lead to an over-pressure condition within the reservoir. A damaged clear cylinder can cause serious injuries when under pressure.** If the reservoir tips or the pressure regulator and/or pressure relief valve otherwise become blocked, **if any cracks can be seen on the clear cylinder**, they must be replaced with SR-TEK supplied or approved parts.

Dropping the reservoir from any height can damage the pressure regulator, pressure relief valve, crack the clear cylinder and damage fittings and/or compromise the integrity of the reservoir body and plates. **A damaged pressure regulator and/or damaged pressure relief valve may lead to an over-pressure condition within the reservoir. A damaged clear cylinder and/or plate can be an explosion hazard.** If the reservoir falls from any height, it must be thoroughly inspected for cracks or damages to the pressure regulator and pressure relief valve. If damage to a component is suspected, it must be replaced with SR-TEK supplied or approved parts.

Tubing Safety

Pressurised tubing can be very dangerous. Tubing whose integrity is compromised due to any kind of wear, damage or misuse can develop a leak, spraying the



contents of the tank at high pressure. This spray can enter the eyes or cover the skin or cause other serious bodily injury, fire or property damage.

Electric Motor Operating Safety

 **DO NOT** use the product in explosive or corrosive environments, in the presence of flammable gases or near combustibles. Doing so may result in fire, electric shock or injury.

ONLY qualified and educated personnel should be allowed to perform installation, connection, operation and inspection/troubleshooting of the product. Handling by unqualified personnel may result in fire, electric shock, injury or equipment damage.

 **DO NOT** transport, install the product, perform connections or inspections when the power is on. Always turn the power and pressure off before carrying out these operations. Failure to do so may result in electric shock or equipment damage.

The terminals on the driver marked with   symbol indicate the presence of high voltage. Do not touch these terminals while the power is on. Doing so may result in fire or electric shock.

The Motor and driver are Class I equipment. When installing the agitated pressure tank, make sure both the motor and driver's terminal are connected to earth. Failure to do so may result in electric shock.

Securely connect and ground in accordance with the connection diagram (page 46). Failure to do so may result in fire or electric shock.

 **DO NOT** forcibly bend, pull or pinch the cables. Doing so may result in fire or electric shock.

 **DO NOT** machine or modify the motor cable or the connection cable. Doing so may result in electric shock or fire.

 **DO NOT** apply excessive force to the motor connector for the connector type. Doing so may result in electric shock or fire.

 **DO NOT** remove the connector cap for the connector type until the connection cable is connected so that the O-ring of the connector connection on the motor is not damaged. Doing so may result in electric shock or fire.

KEEP the input power voltage of the driver within the specified range. Failure to do so may result in fire or electric shock.

 **DO NOT** touch the rotating part (output shaft) when operating the motor. Doing so may result in injury.

MAKE SURE no fluid has been spilt on the motor before operation. If the motor has been in contact with the fluid, disconnect the power immediately and contact

SR-TEK for support. Failure to do so may result in fire, electric shock, injury or equipment damage.

CAUTION The motor surface temperature may exceed **70°C** even under normal operating conditions. If the operators are allowed to approach a running motor, attach a warning label in a conspicuous position. Failure to do so may result in skin burn(s).

Additional Warning Information

A warning label with handling instructions is attached on the driver. Be sure to observe the instructions on the label when handling the driver.



Before pressurising the reservoir:

- 1. BE SURE** all fluid connections to the reservoir are properly secured.
- 2.** Examine all tubing for cuts, wear, bulges and leaks. If any of these conditions exist, replace the tubing immediately with SR-TEK supplied or approved tubing. Do not try to repair a damaged tube.
- 3. BE SURE** that the fluid to be pressurised is compatible with the tubing. Contact the fluid manufacturer and confirm that the fluid is compatible with the tubing material specified on page 46 (Wetted Materials List) of this manual.
- 4. BE SURE** that the tubing will not be exposed to operating temperatures in excess of 38 °C or below 4 °C in the application.

Operating Data

Design pressure:	85psi (5.6bar)
Permissible operating pressure	60psi (4bar)
Test pressure:	90psi (6bar)
Safety valve set pressure	60psi (4bar)
Safety valve inspection number	TÜV SV.10-20557.5D/G
Maximum input pressure	100psi (6.9bar)
Minimum permissible operating temperature	4°C
Maximum permissible operating temperature	38°C
Internal Volume	3.5L, 5.3L and 10.2L
Usable volume*	2L, 5L and 10L
Material/Operating medium	Fluid Group II

* The usable volume refers to the stationary use of the pressure tank. This value does not include any reduction in volume due to internal fittings and/or the use of internal containers (e.g. jars or insert liners). Depending on the operating conditions, the usable volume must be reduced by the operator if necessary in order to avoid damage to the fittings and the internal parts (air inlet, safety devices, agitators, etc.) caused by penetration by the operating medium.

Technical Data

Electric motor BLM Series

Voltage	240V
Frequency	50/60Hz
Output Power	30W
Current	1.5A
Degree of protection	Driver: IP20
Torque	0.10Nm
Start torque	0.144Nm
Free Speed	800rpm
Minimum speed	40rpm
Shaft OD	10mm
Rotation	Clockwise/Anti-clockwise
Rating	ATEX
Motor type	Brushless
Mixing blade	Stainless Steel

Above data are based on 4.0 bar working pressure.

Rules and Regulations for the use of agitated pressure tanks

a. Reservoir

The following information applies only to pressure tanks within the scope of the Pressure Equipment Directive 2014/68/EU. Material pressure tanks that fall below the limit values of Category 1 ("C0", product of pressure PS and volume V lower than 25 bar L) are not covered by the directive.

The 2L, 5L and 10L pressure tanks fall into product group II (Article 4, Clause 3 of PED 2014/68/EU).

Operators must observe and comply with all safety regulations and other rules and regulations relevant for the specific application as well as for the place of use, those regulations imposed by trade and industry law, transport law and water protection law. Before the pressure tank is used for the first time, it is recommended to contact an authorised inspection agency to supervise pressure equipment of the corresponding category in order to determine the rules and regulations covering the specific application and coordinate further procedures.

The pressure tank has been designed, approved and marked by the manufacturer in accordance with the EU Pressure Equipment Directive 2014/68/EU. The category in which the equipment is classified, the scope of the assessment (vessel or assembly) and the applied conformity module can be found in the Certificate of Conformance.

All pressure equipment within the scope of the Pressure Equipment Directive is subject to surveillance in accordance with legislation governing safety of equipment and industrial safety.

Any person using equipment within the scope of the Regulations on Industrial Safety is required to perform an assessment of the dangers involved in using the equipment and to determine the measures necessary to ensure safe installation and operation of the equipment. In particular, this includes those dangers relating to the operation of the equipment itself as well as any dangers at the workplace resulting from interaction with other equipment or with materials or with the working environment.

Any person using pressure equipment is required to keep the equipment in an orderly condition, to operate the equipment in accordance with the rules and regulations, to monitor the condition of the equipment, to perform any necessary maintenance work without delay and to ensure that all the relevant safety measures relating to the specific application have been taken. If the equipment is found to have defects that might endanger its safe operation, it must be taken out of operation immediately.

Pressure equipment is subject to prescribed tests before being put into operation, including after any refitting or maintenance work have been carried out.

Inspection before first use

The pressure tank may be used for the first time only after it has been inspected by an approved inspection agency and has been judged to be in an orderly condition with regards to its assembly, installation, mounting conditions and safe operation.

Recurrent inspections

The pressure equipment must be periodically monitored by the inspection agency at specified intervals to ensure that it is in orderly condition. These inspections consist of internal inspections and strength tests.

Unless otherwise stipulated, internal inspections must be carried out by the inspection agency at least every years, and strength tests must be performed at least every 2 years.

Inspection in special cases

If the pressure tank has been modified in any way, it must not be put into operation again until it has been checked by the notified body and its operation found to be fault-free, so far as it is affected by the modification(s).

If the allowable operating parameters (maximum allowable operating pressure, maximum allowable operating temperature) have been exceeded due to the specific application or as a result of external influences, or if the values have fallen below the minimum levels, the pressure tank must not be put in operation again until it has been checked by the notified body and has been found to be in a fault-free condition. This also applies if the tank has been exposed to fire.

b. Agitator

The agitator is intended for mixing fluids of low and medium viscosities. The electric agitator's speed can be adjusted by manual or automated control of the driver.

The agitator may only be used for the purpose it is designed for.

The observance of the instructions and technical data contained in this manual is mandatory. Other applications shall be implemented only after consulting with SR-TEK.

Dismantling change or replacement of components (accessories and fixtures) is not recommended and can void the warranty. For all repair work, please contact SR-TEK direct.

Usage and operation include reading, understanding and observing all instructions and information contained in this operation manual.

Functional Description

a. Reservoir

In its standard design, an SR-TEK material pressure tank consists of a container with a removable lid, a compressed air inlet fitting assembly comprising of an air pressure regulator with back pressure control, a pressure gauge, a tested safety relief valve, a material outlet fitting (also on the lid).

The tank operates as a feed system to the user's fluid dispensing or spraying device. SR-TEK material pressure tanks are suitable for multiple fluid applications such as dosing, spraying and mixing.

The required delivery pressure or fluid flow rate is adjusted by a pressure regulator with a back-pressure control in the air input side. Once the operating pressure has been set, the tank ensures an even flow of the fluid to the user's device.

b. Agitator

The operation of the tank should be performed under mandatory observance of the instructions described in this operation manual.

The electric motor along with its components must not be disassembled or opened. The prescribed intervals of maintenance and check-up should be observed.

It is the operator's responsibility to make sure the fluid loaded in the tank does not cause the motor to stall. In the event of regular stalling or unusual motor behaviour, contact SR-TEK.

- ① Standard agitated tanks **must not** be used in potentially explosive and hazardous areas.

In general, the agitator assembly is used in a vertical position. It is necessary that the agitator is equipped with a mixing blade or mixing mechanism that is suitable for the fluid used. The mixing blade, which is included in the standard delivery, is suitable for most industry fluids. Other mixing devices can be supplied. For more information, contact SR-TEK.

SR-TEK shall not be held responsible for damages occurred as a result of use of inappropriate mixing mechanisms.

The agitator operation is only allowed when the blade is covered by the fluid.

Avoid axial load of the agitator shaft as it might cause damage to its bearing.

The lifetime of the electric motor is influenced by the hours in operation, the resistance between mixing blade (blade design) and fluid (fluid density) and the settings of the motor driver.

Operation with other gases or liquids is not allowed.

The agitator can only operate under the maximum power and speed set by the driver and as described in the Technical data (page 8). The maximum number of revolutions are specified and set by the manufacturer for best performance and working life.

Other than the settings available on the motor driver, no other adjustment are permitted on this equipment.

**If you have any questions,
please contact us for assistance.**

E-mail technical@sr-tek.com

c. Drivers

Front side When the front panel is attached

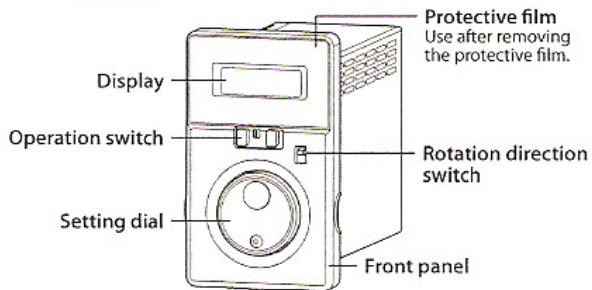

Display	This display shows the monitor item, alarms, etc.
Operation switch	Setting the operation switch to the "RUN" side causes the motor to start running. Setting the operation switch to the "STAND-BY" side causes the motor to stop.
Setting dial	This setting dial is used to change the rotation speed or parameters. After changing, the new value is determined by pressing the setting dial.
Rotation direction switch	This switch is used to change the motor rotation direction.

Rear side

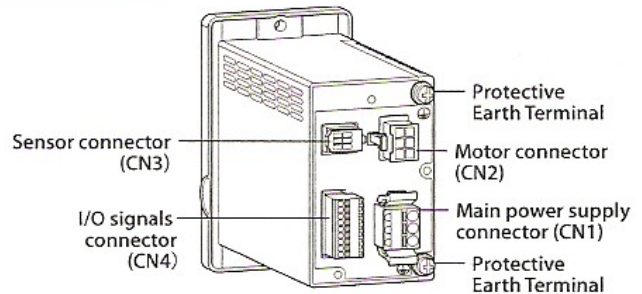

Sensor connector (CN3)	Connects the sensor connector (black) of the motor cable or the connection cable.
I/O signals connector (CN4)	Connects the I/O signals.
Motor connector (CN2)	Connects the power connector (white) of the motor cable or the connection cable.
Main power supply connector (CN1)	Connects the main power supply.
Protective Earth Terminal ⚡	Connects the ground terminal* of the connection cable and the grounding wire. Be sure to ground the driver using either of the Protective Earth Terminals.

* Connector type only

Front side When the front panel is removed

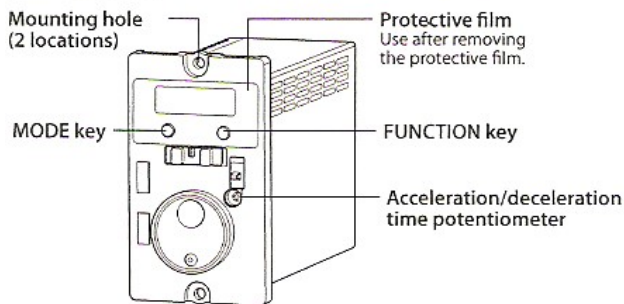

MODE key	This key is used to change the operation mode.
FUNCTION key	This key is used to change the display of the operation mode or the function.

Removing and installing the front panel

Installing

Install the front panel after placing on the upper side of the driver front face.

Removing

Remove the front panel having the under side.

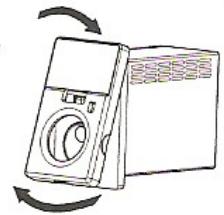

Acceleration/deceleration time potentiometer	This potentiometer is used to set the acceleration/deceleration time.
Mounting hole (2 locations)	Installs the driver with screws (M4 or No.8-32UNC).

If you have any que: ^{page 13}
please contact us for assistance.

E-mail technical@sr-tek.com

2000ML-CTEL Exploded View

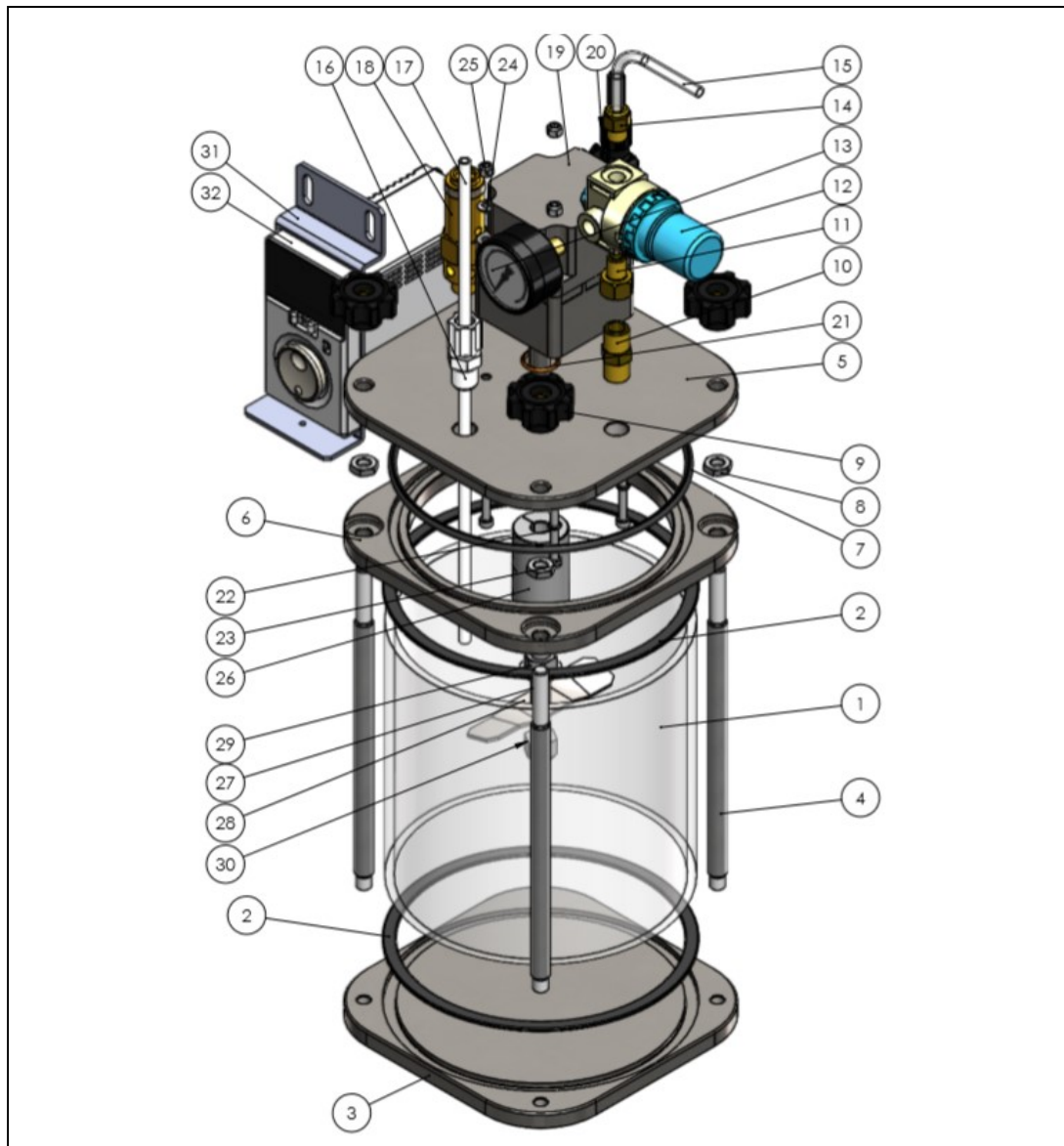

2000ML Specifications

Capacity:	2 litre
Maximum Operating Pressure:	4 bar (60 psi)
Maximum Operating Temperature:	38 °C
Minimum Operating Temperature:	4°C
Weight (Acrylic cylinder):	7.0 kg
Height:	285 mm
Dimension Lid:	166 mm

2000ML-CTEL Replacement Parts

Part number	Description	Quantity
1. 2008	Toughened Glass or Acrylic Cylinder 2L	1
2. 2009	Viton Flat Seal	2
3. 2010	Base Plate	1
4. 518	Rod	4
5. 2019-EL	2L Lid with Electric Motor	1
6. 2020	Top Plate	1
7. OR-4-148	O-ring Viton 148x4	1
8. NM8SS	Nut Stainless Steel M8	4
9. NM8PLSTAR	Star Grip M8	4
10. HNIPPLE0.25	Nipple Fitting 1/4" NPT	1
11. HADAPTER.25-M.125	1/8 Male 1/4 Female BSP Nipple Adapter	1
12. HREGULATORAIR60	Air Pressure Regulator 0-60psi	1
13. AN-60-G	Pressure Gauge 0-60psi	1
14. HADAPTER0.125-6	Air Pressure Regulator 0-60psi	1
15. 6PE-CL	Fluid tubing 6mm Clear (not supplied)	1
16. FIT-0.25-COMP-6	Compression Adapter 1/4NPT 6mm	1
17. 6PE-WH-0.5L	Clear tubing 6mm (not supplied)	1
18. 60-SV	Safety valve 0.25 60psi	1
19. 1026	Electric Motor 30W	1
20. 1027	Electric Cable Controller-Motor	1
21. OR-2-16	Viton O-ring 16 x 2.0	1
22. W4.5SSBONDED	Bonded seal 4.5	1
23. 91292A269	M4x0.8 70L stainless steel cap head bolt	4
24. 93237A106	Belleville spring lock washer M4	4
25. 93625A150	M4 stainless nylon lock nut	4
26. HCOUPLING 1010	Shaft coupler 10 10	1
27. 1021	Mixing shaft	1
28. 1022-P11	Mixing blade single	1
29. NM10SSFLANGE	Flange nut M10	1
30. NM10SSLOCK	Locking nut M10	1
31. 1028	Driver bracket	1
32. 1029	Driver	1

Accessories

Part number	Description
2000ML-JAR	Plastic jar
1022-Pxx	Alternative mixing blade
2L-SHELF-SS	Vessel supporting shelf
5L-SHIELD-SS	Vessel housing shell

5000ML-CTEL Exploded View

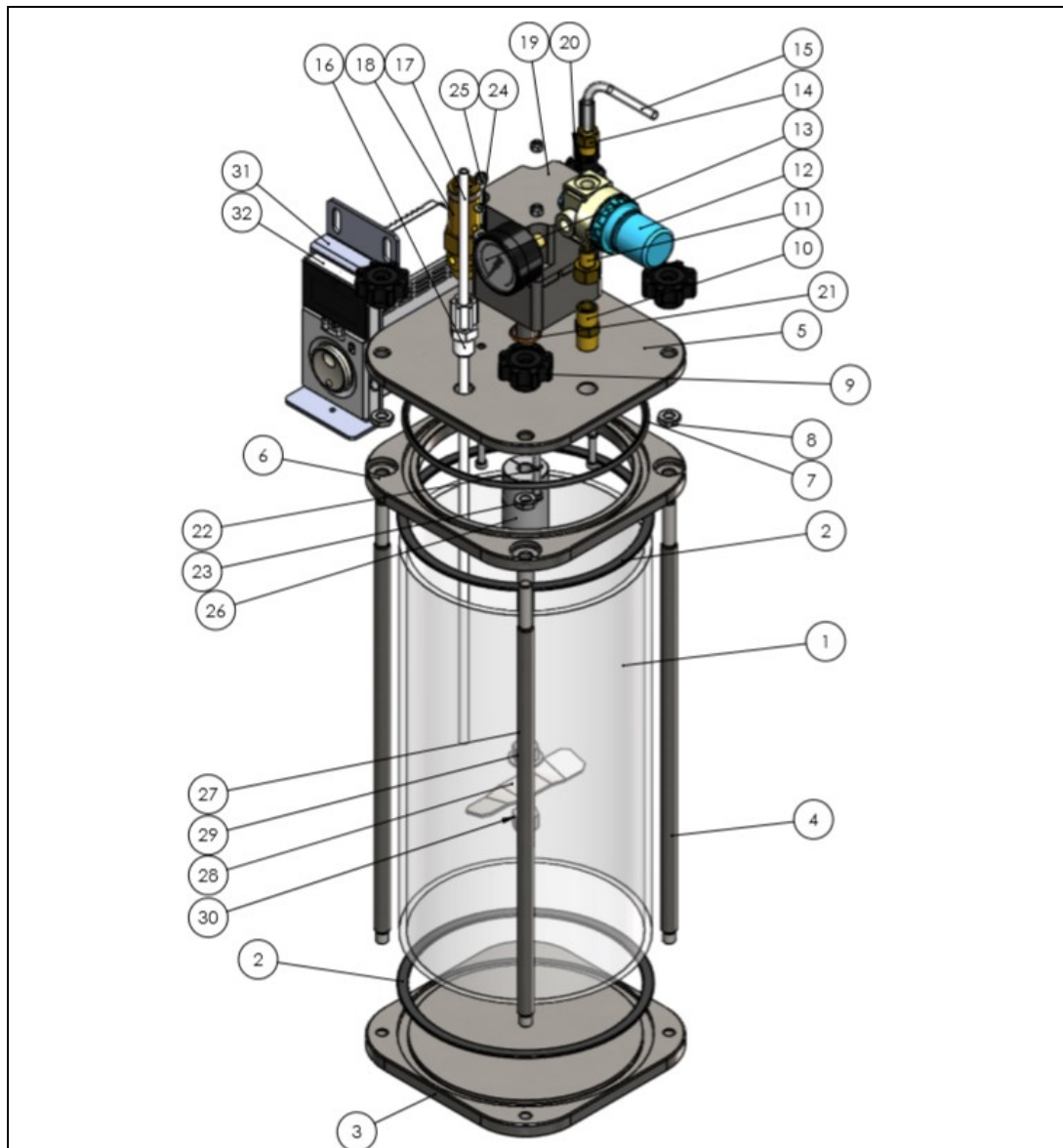

5000ML Specifications

Capacity:	5 litre
Maximum Operating Pressure:	6.9 bar (100 psi)
Maximum Operating Temperature:	38 °C
Minimum Operating Temperature:	4°C
Weight (Acrylic cylinder):	7.6 kg
Height:	425 mm
Dimension Lid:	166 mm

5000ML-CTEL Replacement Parts

Part number	Description	Quantity
1. 5025	Toughened Glass or Acrylic Cylinder 5L	1
2. 2009	Viton Flat Seal	2
3. 2010	Base Plate	1
4. 5026	Rod	4
5. 2019-EL	2L Lid with Electric Motor	1
6. 2020	Top Plate	1
7. OR-4-148	O-ring Viton 148x4	1
8. NM8SS	Nut Stainless Steel M8	4
9. NM8PLSTAR	Star Grip M8	4
10. HNIPPLE0.25	Nipple Fitting 1/4" NPT	1
11. HADAPTER.25-M.125	1/8 Male 1/4 Female BSP Nipple Adapter	1
12. HREGULATORAIR60	Air Pressure Regulator 0-60psi	1
13. AN-60-G	Pressure Gauge 0-60psi	1
14. HADAPTER0.125-6	Air Pressure Regulator 0-60psi	1
15. 6PE-CL	Fluid tubing 6mm Clear (not supplied)	1
16. FIT-0.25-COMP-6	Compression Adapter 1/4NPT 6mm	1
17. 6PE-WH-5L	Clear tubing 6mm (not supplied)	1
18. 60-SV	Safety valve 0.25 60psi	1
19. 1026	Electric Motor 30W	1
20. 1027	Electric Cable Controller-Motor	1
21. OR-2-16	Viton O-ring 16 x 2.0	1
22. W4.5SSBONDED	Bonded seal 4.5	1
23. 91292A269	M4x0.8 70L stainless steel cap head bolt	4
24. 93237A106	Belleville spring lock washer M4	4
25. 93625A150	M4 stainless nylon lock nut	4
26. HCOUPLING 1010	Shaft coupler 10 10	1
27. 2021	Mixing shaft	1
28. 1022-P11	Mixing blade single	1
29. NM10SSFLANGE	Flange nut M10	1
30. NM10SSLOCK	Locking nut M10	1
31. 1028	Driver bracket	1
32. 1029	Driver	1

Accessories

Part number	Description
5000ML-JAR	Plastic jar
1022-Pxx	Alternative mixing blade
2L-SHELF-SS	Vessel supporting shelf
5L-SHIELD-SS	Vessel housing shell

1000CL-CTEL Exploded View

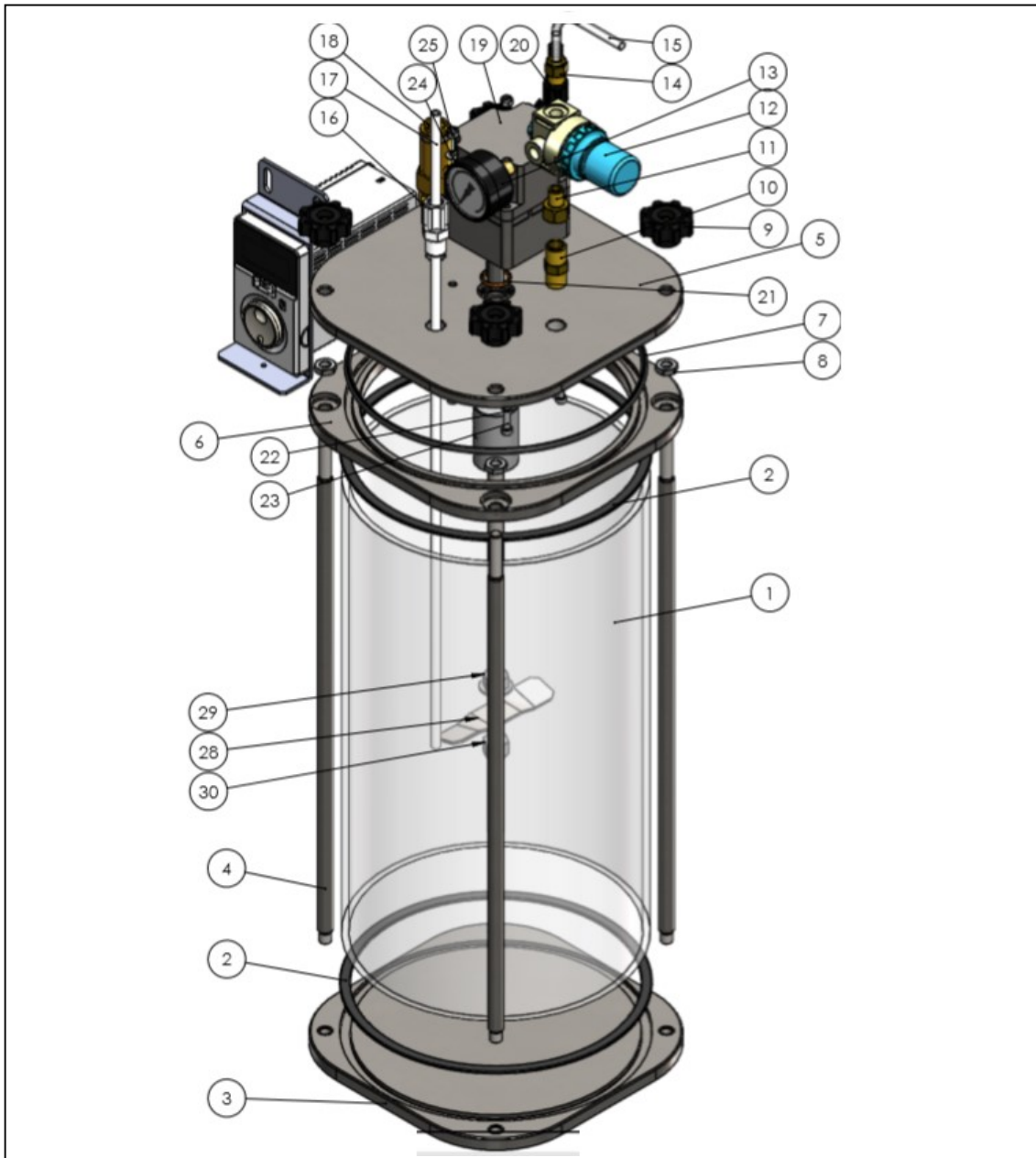

1000CL Specifications

Capacity:	10 litres
Maximum Operating Pressure:	4 bar (60psi)
Maximum Operating Temperature:	38 °C
Minimum Operating Temperature:	4°C
Weight (Acrylic cylinder):	8.1 kg
Height:	385 mm
Dimension Lid:	206 mm

1000CL-CTEL Replacement Parts

Part number	Description	Quantity
1. 1050	Toughened Glass or Acrylic Cylinder 10L	1
2. 1052	Viton Flat Seal	2
3. 1053	Base Plate	1
4. 1051	Rod	4
5. 1054-EL	Lid with Electric Motor	1
6. 1055	Top Plate	1
7. OR-4-188	O-ring Viton 188x4	1
8. NM8SS	Nut Stainless Steel M8	4
9. NM8PLSTAR	Star Grip M8	4
10. HNIPPLE0.25	Nipple Fitting 1/4" NPT	1
11. HADAPTER.25-M.125	1/8 Male 1/4 Female BSP Nipple Adapter	1
12. HREGULATORAIR60	Air Pressure Regulator 0-60psi	1
13. AN-60-G	Pressure Gauge 0-60psi	1
14. HADAPTER0.125-6	Air Pressure Regulator 0-60psi	1
15. 6PE-CL	Fluid tubing 6mm Clear (not supplied)	1
16. FIT-0.25-COMP-6	Compression Adapter 1/4NPT 6mm	1
17. 6PE-WH-10L	Clear tubing 6mm (not supplied)	1
18. 60-SV	Safety valve 0.25 60psi	1
19. 1026	Electric Motor 30W	1
20. 1027	Electric Cable Controller-Motor	1
21. OR-2-16	Viton O-ring 16 x 2.0	1
22. W4.5SSBONDED	Bonded seal 4.5	1
23. 91292A269	M4x0.8 70L stainless steel cap head bolt	4
24. 93237A106	Belleville spring lock washer M4	4
25. 93625A150	M4 stainless nylon lock nut	4
26. HCOUPLING 1010	Shaft coupler 10 10	1
27. 2021	Mixing shaft	1
28. 1022-P11	Mixing blade single	1
29. NM10SSFLANGE	Flange nut M10	1
30. NM10SSLOCK	Locking nut M10	1
31. 1028	Driver bracket	1
32. 1029	Driver	1

Accessories

Part number	Description
1000CL-JAR	Plastic jar
1022-Pxx	Alternative mixing blade

Precautions for use

This chapter covers limitations and requirements the user should consider when using the product.

Be sure to match the motor output power with the driver output power.

Connect protective devices to the power line

Connect a circuit breaker or earth leakage breaker to the driver's power line to protect the primary circuit. If an earth leakage breaker is to be installed, use one incorporating high-frequency noise elimination measures. Refer to "Preventing leakage current" below for the selection of protective devices.

⚠ Do not use a solid-state relay (SSR) to turn on/off the power

A circuit that turns on/off the power via a solid-state relay (SSR) may damage the motor and driver.

⚠ Do not conduct the insulation resistance measurement or dielectric strength test with the motor and driver connected

Conducting the insulation resistance measurement or dielectric strength test with the motor and driver connected may result in damage to the product.

Grease measures

On rare occasions, grease may ooze out from the gearhead. If there is concern over possible environmental damage resulting from the leakage of grease, check for grease stains during regular inspections. If leakage happens frequently and leads to problems in production, contact SR-TEK for support.

Caution when using under low temperature environment

When an ambient temperature is low, since the load torque may increase by the oil seal or viscosity increment of grease used in the gearhead, the output torque may decrease or an overload alarm may generate. However, as time passes, the oil seal or grease is warmed up, and the motor can be driven without generating an overload alarm.

Preventing leakage current

Stray capacitance exists between the driver's current-carrying line and other current-carrying lines, the earth and the motor, respectively. A high-frequency current may leak out through such capacitance, having a detrimental effect on the surrounding equipment. The actual leakage current depends on the driver's switching frequency, the length of wiring between the driver motor, and so on. When connecting an earth leakage breaker, use one of the following products offering resistance against high frequency current:

Mitsubishi Electric Corporation: NV Series

Noise elimination measures

Provide noise elimination measures to prevent a motor or driver malfunction caused by external noise. For more effective elimination of noise, use a shielded I/O signal cable or attach ferrite cores if a non-shielded cable is used.

Connecting the motor and driver

Be sure to connect the connector type motor and the driver using the dedicated connection cable supplied with the equipment.

Do not apply a strong force on the locking lever of the connector for motor connection. Applying a strong force on the locking lever may cause damage.

The driver uses semiconductor elements, so be extremely careful when handling them

Electrostatic discharge can damage the driver

Be sure to ground the motor and driver to prevent them from being damaged by electric shock or static electricity.

Conditions of use

a. Reservoir

Material pressure tanks are designed to be used for delivering low to medium viscosity fluids and materials that are put under pressure by a gas (compressed air and other inert gases).

The tank must be used only within the operating parameters specified in the Operating data (page 8 of this manual).

SR-TEK undertakes the responsibility for the device subject of delivery (e.g. for the pressure device and other components of the equipment supplied). Operators are obliged to observe the applicable regulations, instructions and be personally responsible for the equipment.

This implies that operators have read, understood and observed all instructions set out in this manual. SR-TEK Ltd cannot be held responsible for property damages, injuries or any other form of losses if operating and safety instructions described in this manual have not been followed.

Before filling the tank, make sure the fluid is compatible with all wetted parts of the equipment. Information about fluid compatibility can be found on page 3 of this manual and technical data sheet of the fluid manufacturer. In doubt, please contact SR-TEK for compatibility check. Follow the safety instructions provided by the fluid manufacturer during filling operation.

The pressure tank must not be operated solely with liquid pressure (e.g. filled to the top flange).

 The pressure tank must not be pressurised using toxic, flammable or aggressive gases. Pressurising the tank with pure oxygen is strictly prohibited:

RISK OF EXPLOSION!

The pressure tank **must not** be operated with nitrogen unless additional safety devices have been fitted.

The pressure tanks **must not** be used for transporting materials. Exceptions are permissible only if suitable measures have been taken by the customer to allow the tank being used at various locations within the same plant.

The pressure tank **must not** be used for long-term storage of materials.

The pressure tank **must not** be used for materials that are incompatible with the tank and all other wetted parts in the tank.

No changes or modifications should be made to the pressure tank and its components prior consulting SR-TEK.

The components and accessories fitted to the tank (safety valve, regulator, gauge, etc...) **must not** be changed or tempered with. The tank should be protected against dirt and contamination.

b. Agitator

The agitators are meant for vertical assembly over pressure tanks containing fluids.

SR-TEK products are supplied fully assembled. The electric motor agitator assembly is fitted prior supply to ensure airproof seal between motor and lid. The electric agitator consists of an electric motor with gears, O-ring, shaft coupler, shaft and mixing blade. The electric motor is operated using a remote driver, also supplied with the tank. The revolutions and moment of rotation are specified and regulated through the motor driver.

The motor requires single phase 240V connection to the factory's power supply. It is recommended to have trained operators or maintenance engineers performing the installation.

Provide an emergency stop device or emergency stop circuit external to the equipment so that the entire equipment will operate safely in the event of a system failure or malfunction. Failure to do so may result in injury.

Use an insulated screwdriver to adjust the acceleration/deceleration time potentiometer in the driver. Failure to do so may result in the electric shock.

**If you have any questions,
please contact us for assistance.**

E-mail technical@sr-tek.com

Instructions

- ① Read carefully this operation manual before handling the device and before putting it into operation.

This operation manual is part of the product and should be kept close to it. The product should always be used by trained operators.

Observe all the safety instructions from this manual to avoid damage to the equipment and risk to the operators and staff working in close proximity of the pressure tank.

If the tank is placed in an area with risk of electrostatic charges, the pressure tank, the air line, fluid line, motor, mixer, driver and all electric conductive surfaces within the working area of the tank must be earthed. Failure to do so may result in fire or damage to equipment.

For the power supply I/O signals, use a DC power supply with reinforced insulation on its primary and secondary sides. Failure to do so may result in electric shock.

Technical details of the specific modifications and construction may differ from this manual. In any doubt, contact us for further clarification.

The agitated reservoir should be supplied fully assembled. Upon reception, the product should be checked for:

- Any visible damages from storage or transportation. Special attention must be paid to body parts including shaft, seals, lid and all components pre-installed on the reservoir.
- Oil leakage
- Signs of corrosion resulting of improper storage or storage in humid environment.
- Packaging materials damaged or removed.

Air quality and connection conditions

We strongly recommend the use of 5µm coalescing filter to achieve clean and dry compressed air. Prescribed air quality as per DIN ISO 8573-1, Quality Class 4.

We recommend using the following:

- Residual maximum dust particle size: 5µm
- Residual maximum dust concentration: 8mg/m³
- Residual maximum humidity concentration: 6g/m³

Be aware of pressure drop and therefore performance drop when using air tubing over 3 meters long.

a. Operating the motor direct from the driver

This section explains how to operate the motor from the driver.

After turning on the power, operate the driver as follow:

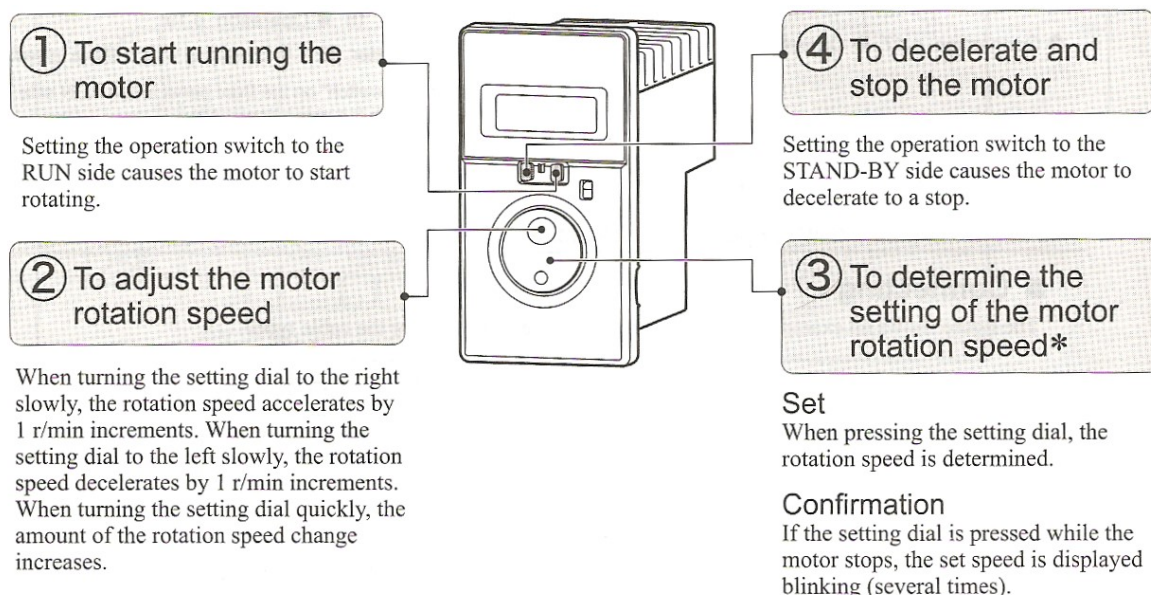

Setting the operation switch to RUN causes the motor to start rotating at the set rotation speed.

- When inputting the power, if the operation switch is set to RUN, the alarm code “AL 46” (prevention of operation at power-on) is displayed, and the operation cannot be executed.
- Set the operation switch to the STAND-BY side and turn on the power.

* When the display is blinking, the rotation speed has not yet been set. Select it by pressing the setting dial.

(The set data is saved in the operation data No. 0. Refer to page 39 for details).

Operating with the setting dial can be limited by the lock function so that the set rotation speed cannot be changed.

Refer to “7.7 Data locking for the set data” on page 40 for details.

Saving data to the non-volatile memory

The display blinks while pressing the setting dial to set the data or initializing the data (about 5 seconds). Do not turn off the power supply while the display is blinking. Doing so may abort writing the data and cause an EEPROM error alarm to generate. The non-volatile memory can be rewritten approximately 100,000 times.

b. Changing the rotation direction

Change the rotation direction of the motor and gearhead using the rotation direction switch. The rotation direction can be changed while operating.

In case of the gearhead output shaft, the rotation direction varies depending on the gear ration of the gearhead.

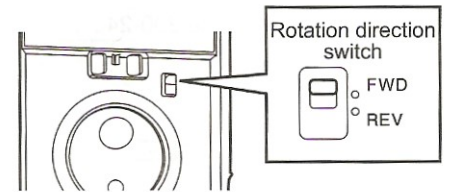

c. Operating the motor from a PLC

The motor can be operated and stopped via a PLC.

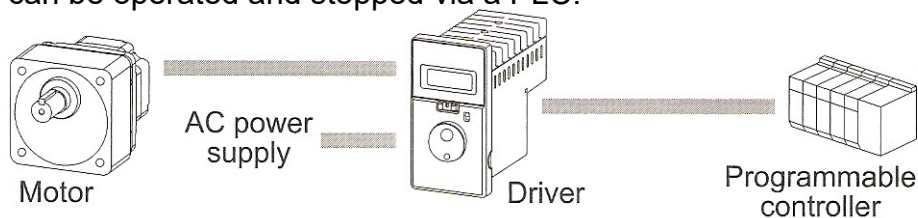

When the motor is operated and stopped externally, the “external operation signal input” parameter (ioEn) is required to change.

After connecting the operation input signals (FWD input, REV input) to the CN4, set and operate the product as follow:

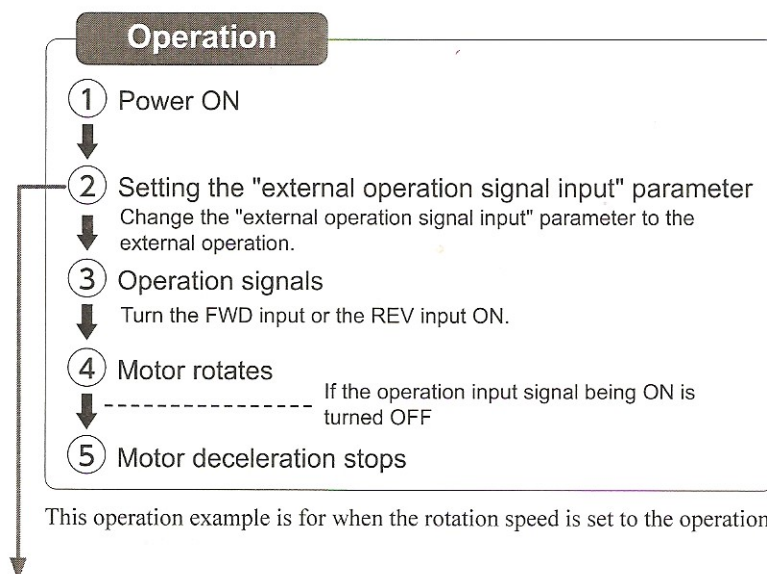

To set the “external operation signal input” parameter to external operation (ioEn) when operating and stopping the motor via PLC.

- “OFF at the time of shipment: The operation using the front panel is set.
- Change the “ON” or “rE” for the setting of external operation.

Setting range:

Off: Operation/standstill using front panel (Factory setting)

On: Operation/standstill using external signals (The operation with the front panel is Enabled)

rE: Operation/standstill using external signals (The operation with the front panel is Disabled.)

The “external operation signal input” parameter (ioEn) is found in the parameter mode page 32).

Front panel operation:

Operation using the switches and setting dial on the front panel can be set to

“Enable: O” or “Disable: x”.

Setting	Operation switch	Rotation direction switch	Setting dial
On	O	O	O
rE	x	x	x *

* The data mode, parameter mode, and the I/O monitor of the monitor mode are enabled (possible to set).

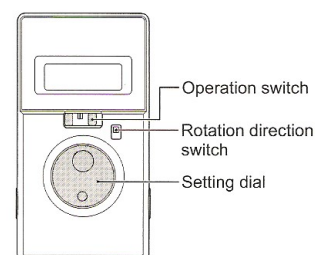

When the setting is “ON”

Operation by switches on the front panel: Enable

When turning the operation input signal ON, while the operation switch is Set to the RUN side, the motor rotates.

When the operation switch is set to the “STAND-BY” side, the motor decelerates to a stop even if the operation input signal is being ON.

Turning the setting dial changes the motor rotation speed.

If the rotation direction switch is changes, the motor rotates in the opposite direction.

When the setting is “RE”

Operation by switches on the front panel: Disable

If the operation switch or rotation direction switch are operated while setting to “RE”, “rE”, will be displayed.

Also, if the setting dial is operated while displaying the rotation speed, alarm, or warning in the motor mode, “rE” will be displayed.

The data mode, parameter mode, and the I/O monitor of the monitor mode are enabled (possible to set).

The display time of “rE” varies depending on the switch.

- When setting the operation switch to the “RUN” side, “rE” will be displayed continuously.
- When switching the rotation direction switch to “FWD” (or “REV”), or when operation the setting dial, “rE” will be displayed for two seconds.

d. Operation and Stop

Operation

The motor rotates when either FWD input or REV input is turned ON.

Stop

There are two stopping methods.

Deceleration stop: if the signal being ON is turned OFF, the motor decelerated to a stop.

Instant stop: if FWD input and REV input are turned ON simultaneously, the motor stops instantaneously.

Below is an example of time chart for when the “external operation signal input” parameter is set to “ON” and the rotation direction switch is set to “FWD” side.

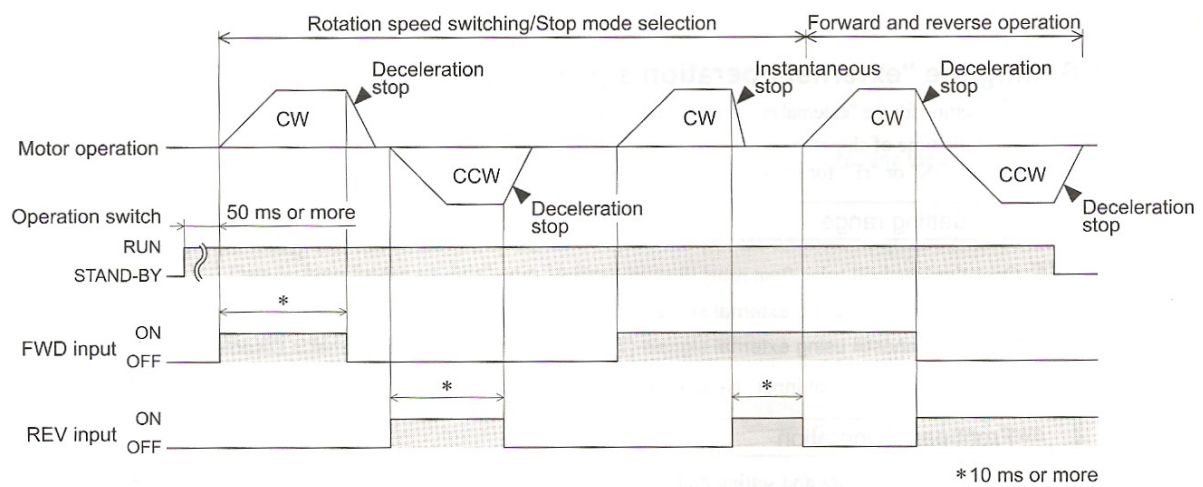

e. Switching the motor rotation direction

When turning the FWD input or REV input ON, the motor rotation direction varies depending on the state of the rotation switch. The rotation direction shown on the side figure is as viewed from the motor input shaft.

Rotation direction switch	External operation input	
	FWD input	REV input
"FWD" side 	Motor rotation direction: <u>Clockwise</u> 	Motor rotation direction: <u>Counterclockwise</u>
"REV" side 	Motor rotation direction: <u>Counterclockwise</u> 	Motor rotation direction: <u>Clockwise</u>

If the rotation direction switch is changed, the motor will decelerate to a stop and start rotating in the direction being switched.

If the “external operation signal input” parameter is set to “RE”, the rotation direction switch will be disabled.

The rotation direction at which “RE” was set is the same direction as the “FWD” side in the figure above.

Rotation direction of the gearhead output shaft

The rotation direction of the gearhead output shaft varies depending on the type or the gear ratio of the gearhead. Check the operating manual supplied with the motor for the rotation direction of the gearhead output shaft.

f. Function list

The following functions are available for this product

	Functions	Description
D i s p l a y	Rotation speed	Displays the rotation speed of the motor output shaft.
		Displays by converting the motor rotation speed into the rotation speed of the gearhead output shaft.
	Conveyor transfer speed	Displays by converting the motor rotation speed into the transfer speed of the conveyor drive.
	Speed increasing	Displays by converting the motor rotation speed into the increasing speed.
	Load factor	Displays the load torque applied on the motor output shaft as a percentage (%).
	Operation data No.	Displays the operation data number that is presently operating.
	Alarm	Displays the alarm information by the alarm code.
		Displays the alarm records.
	Warning	Displays the warning information by the warning code.
		Displays the warning records.
I/O signals	Checks whether a signal is input.	
	Checks whether a signal is output.	
S e t t i n g	Rotation speed	Sets the motor rotation speed using the setting dial.
		Sets the motor rotation speed in the operation data.
	Acceleration time, deceleration time	Sets using the acceleration/deceleration time potentiometer.
		Sets in the operation data.
	Lock function	Disables an operation with the setting dial so that the set data cannot be changed.
	Operation using programmable controller	Operates by inputting signals externally.
		Disables an operation with the setting dial on the front panel.
		Operates with multiple speeds. (Up to 4 speeds)
	Limiting the setting range of the rotation speed	Sets the upper limit and lower limit of the rotation speed.
	Slight position-keeping	The load position can be kept at motor standstill.
Changing the function for I/O signals	Changes the functions assigned to the input signals (5 input signals).	
	Changes the functions assigned to the output signals (2 output signals).	
Initial display at power ON	Changes the display item when turning on the power.	
Data initialization	Restores the operation data to the factory setting (initial value).	
	Restores the parameter setting to the factory setting (initial value).	

g. Setting items and panel displays

The display is lit **50**

This is a state being set.
After the setting was changed, it is determined when the display changes from blinking to lighting.

The display blinks **50**

The setting can be changed while the display blinks.

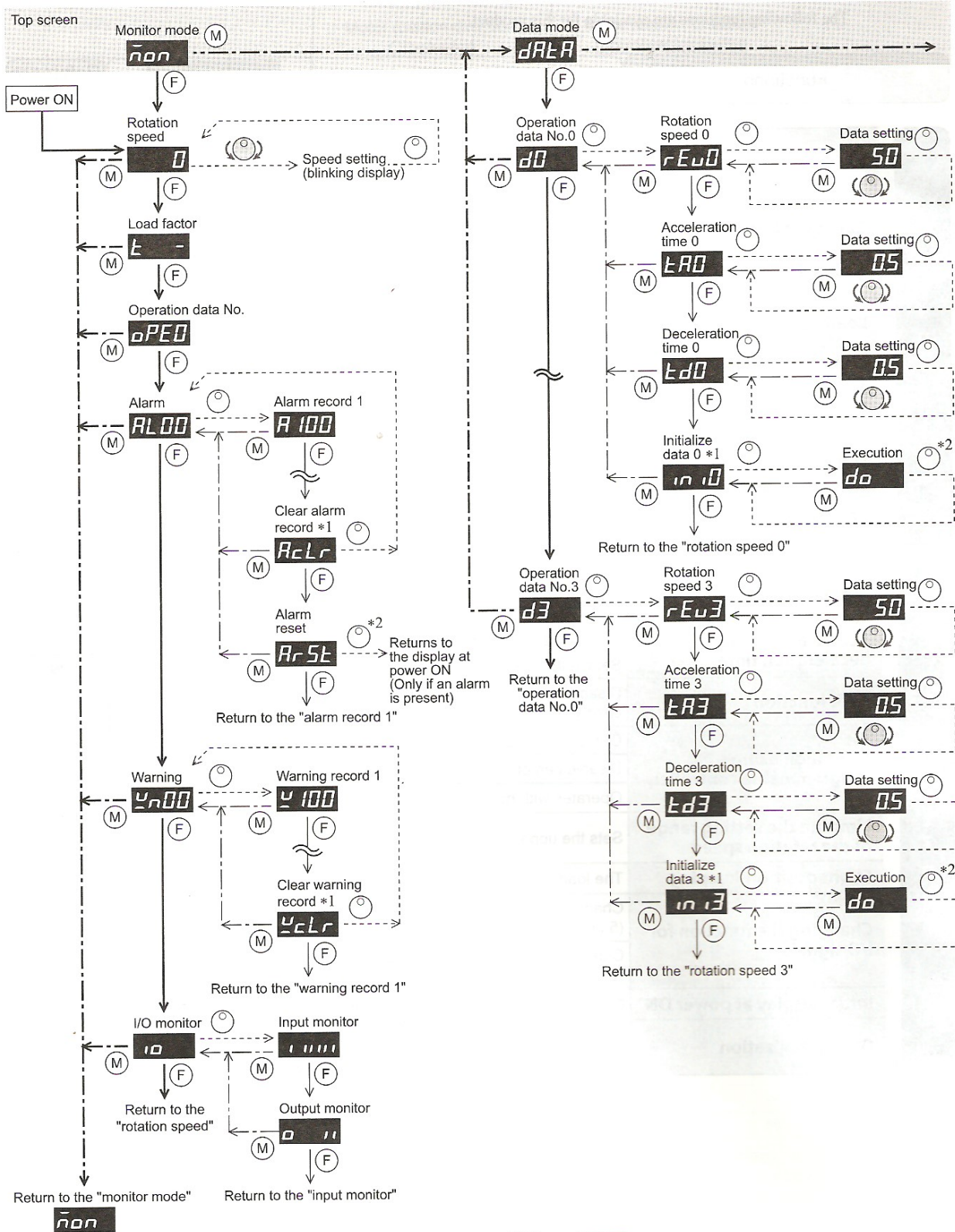

The display for when turning on the power can be changed using the "panel initial view" parameter.

Explanation of graphic symbols

When the front panel is removed

(M) : Press the MODE key

(F) : Press the FUNCTION key

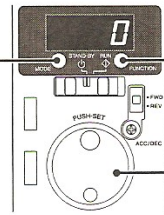

Setting dial (○) : Turn the setting dial
 (○) : Press the setting dial

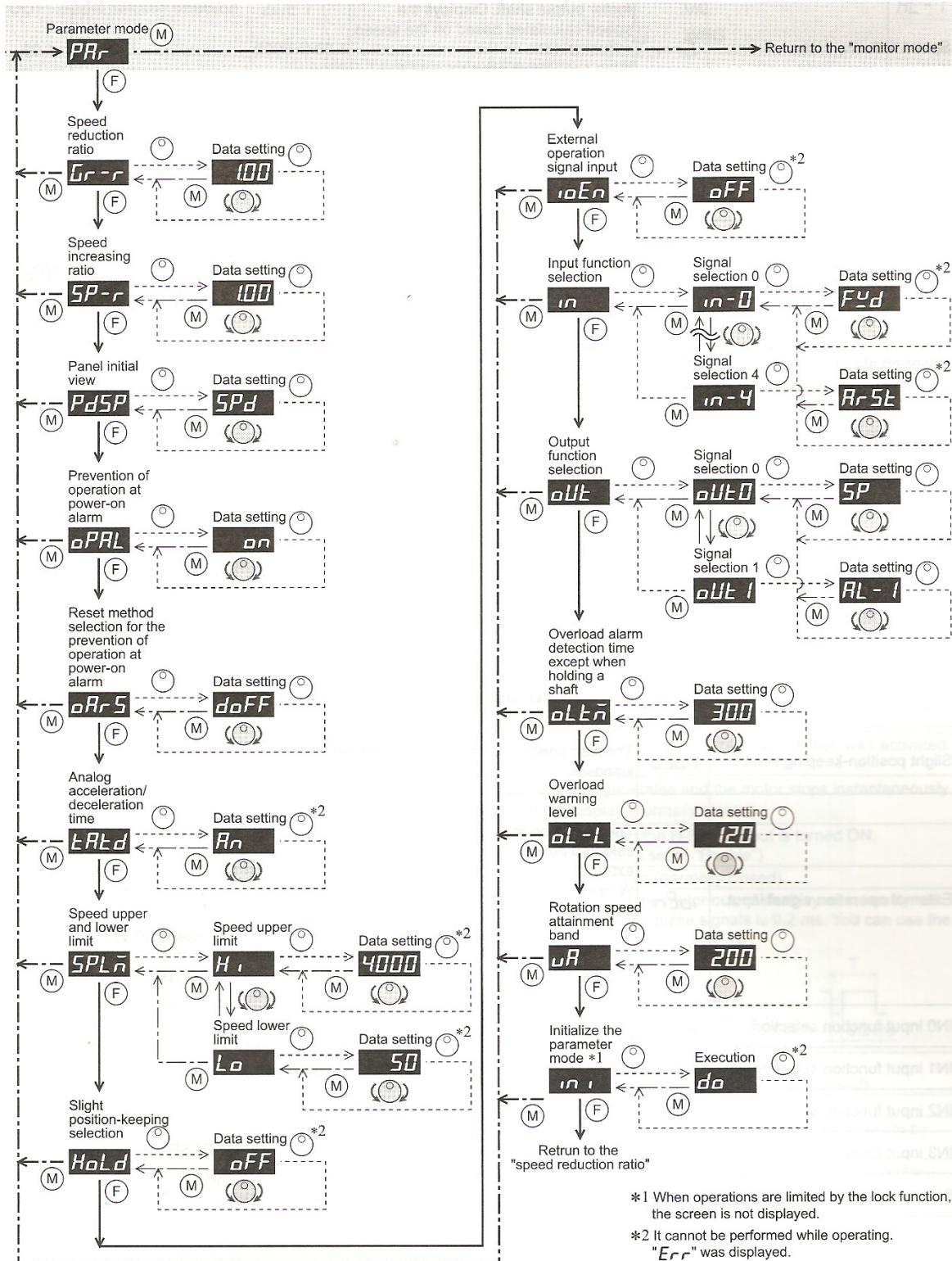

h. Parameter list

Operation mode: Parameter mode

Item	Display	Description	Setting range	Factory setting
Speed reduction ratio	$\overline{S}r-r$	Sets the speed reduction ratio relative to the rotation speed of the motor output shaft. Displays the speed calculated based on the speed reduction ratio on the monitor mode. If the speed reduction ratio for the conveyor is calculated and input, the conveyor transfer speed can also be displayed.	1.00 to 9999	1.00
Speed increasing ratio	$\overline{S}P-r$	When increasing the motor rotation speed using the external mechanism and others, the converted speed can be displayed.	1.00 to 2.00	1.00
Panel initial view	$\overline{P}d\overline{S}P$	After the power is turned on, the item displayed on the monitor mode can be changed.	$\overline{S}Pd$ Rotation speed (r/min) $\overline{L}r\overline{q}$ Load factor (%) $\overline{d-no}$ Operation data No.	$\overline{S}Pd$
Prevention of operation at power-on alarm	$\overline{o}P\overline{A}L$	Sets whether to enable or disable the "prevention of operation at power-on alarm." Refer to p.32 for alarms.	$\overline{o}FF$ Disable $\overline{o}n$ Enable	$\overline{o}n$
Reset method selection for the prevention of operation at power-on alarm	$\overline{o}R\overline{S}$	Selects how to reset the prevention of operation at power-on alarm.	$\overline{d}o\overline{F}F$ Resets by turning the FWD or REV input OFF or by setting the operation switch to the STAND-BY side. $\overline{R}r\overline{S}t$ Resets using the ALARM-RESET input or the alarm reset on the monitor mode.	$\overline{d}o\overline{F}F$
Analog acceleration/ deceleration time	$\overline{L}A\overline{L}d$	Changes the setting method of acceleration/deceleration time.	$\overline{A}n$ Using the acceleration/ deceleration time potentiometer (analog) $\overline{d}i\overline{G}$ Sets using the operation data(digital)	$\overline{A}n$
Speed upper and lower limit	Speed upper limit $\overline{S}P\overline{L}\overline{n}$	$\overline{H}i$ Sets the upper limit of the rotation speed.	50 to 4000	4000
	Speed lower limit	$\overline{L}o$ Sets the lower limit of the rotation speed.		50
Slight position-keeping selection	$\overline{H}o\overline{L}d$	The load position can be kept at motor standstill.	$\overline{o}FF$ Disable $\overline{o}n$ Enable	$\overline{o}FF$
External operation signal input	$\overline{i}o\overline{E}n$	The operation method can be selected between the front panel and external input signals. When operating or stopping the motor using the external input signals, the functions of the operation switch, rotation direction switch, and setting dial can be set to disable.	$\overline{o}FF$ Operation/standstill using front panel $\overline{o}n$ Operation/standstill using external signals (Front panel operation: Enable) $\overline{r}E$ Operation/standstill using external signals (Front panel operation: Disable)	$\overline{o}FF$
IN0 input function selection	$\overline{i}n-0$	Assigns the input signals to the external input terminals.	$\overline{---}$ Not used	$\overline{F}wd$
IN1 input function selection	$\overline{i}n-1$		$\overline{F}wd$ FWD $\overline{r}Ev$ REV	$\overline{r}Ev$
IN2 input function selection	$\overline{i}n-2$		$\overline{n}0$ M0 $\overline{n}1$ M1	$\overline{n}0$
IN3 input function selection	$\overline{i}n-3$		$\overline{R}r\overline{S}t$ ALARM-RESET $\overline{E-}Er$ EXT-ERROR	$\overline{n}1$
IN4 input function selection	$\overline{i}n-4$		$\overline{H-Fr}$ H-FREE	$\overline{R}r\overline{S}t$

Item	Display	Description	Setting range	Factory setting
OUT0 output function selection	<i>OUT0</i>	Assigns the output signals to the external output terminals.	---- Not used <i>AL-1</i> ALARM-OUT1 <i>SP</i> SPEED-OUT	<i>SP</i>
OUT1 output function selection	<i>OUT1</i>		<i>AL-2</i> ALARM-OUT2 <i>MOVE</i> MOVE <i>VA</i> VA <i>WNG</i> WNG	<i>AL-1</i>
Overload alarm detection time except when holding a shaft	<i>OLLn</i>	Sets the time to output the alarm after detecting the overload condition when a load up to the limited duty region exceeding the continuous duty region was applied.	0.1 to 60.0 s	30.0
Overload warning level	<i>OL-L</i>	Sets the detection level (load factor) for the overload warning function based on the rated current being 100%.	50 to 120%	120
Rotation speed attainment band	<i>WR</i>	Sets the band within which the rotation speed of the motor is deemed to have reached the set value.	0 to 400 r/min	200
Initialize the parameter mode	<i>IN1</i>	Restores the value set in the parameter mode to the factory setting.	-	-

Note

- Do not turn off the motor while the initialization is still in progress (= while the display is blinking)
- When setting the speed increasing ratio to 1.00, the speed reduction will be effective. When setting the speed increasing ratio to other than 1.00, the speed increase ratio will be effective.
- When setting a longer time in the “overload alarm detection time except when holding a shaft” parameter, an overload status may continue. Repeating this condition may result in shorter service life of the motor and gearhead.
- If a load exceeding the limited duty region was applied or the output shaft was locked, the “overload alarm detection time except when holding a shaft” is a maximum 5 seconds.

i. Description of I/O signals for 1, 2 and 5L tank Drivers

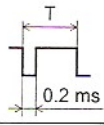
Signal	Terminal	Signal name	Description
Input	X0 X1 X2	FWD	The motor rotates when either of the FWD input or REV input is turned ON. If the FWD input and REV input are turned ON simultaneously, the motor stops instantaneously.
		REV	
		M0	These signals are used to select the operation data number.
		M1	If both signals are turned OFF, the operation data No.0 is selected.
		ALARM-RESET	This signal is used to reset the present alarm when a protective function was activated. Refer to p.34 for timing chart.
		EXT-ERROR	When turning this signal OFF, an alarm generates and the motor stops instantaneously. Then "ALBE" will be shown on the display (normally closed).
		H-FREE	The slight position-keeping is released when the H-FREE input is turned ON. (When the slight position-keeping selection is set to "Enable")
Output	Y0 Y1	ALARM-OUT1	This signal is output when an alarm generates (normally closed).
		SPEED-OUT	30 pulses are output with each revolution of the motor output shaft synchronously with the motor operation. The pulse width of output pulse signals is 0.2 ms. You can use the SPEED-OUT output to calculate the motor speed. $\text{SPEED-OUT output frequency (Hz)} = \frac{1}{T}$ $\text{Rotation speed (r/min)} = \frac{\text{SPEED-OUT output frequency}}{30} \times 60$ 
		ALARM-OUT2	This signal is output when exceeding the overload warning level. Or this signal is output when an overload alarm generates (normally closed).
		MOVE	This signal is output while the motor is operating.
		VA	This signal is output when the motor rotation speed becomes equal the value set by the rotation speed attainment band parameter.
		WNG	This signal is output when a warning generates. (The motor will continue to operate.) When the warning is released, it will automatically turn OFF.

j. Description of I/O signals for 10 and 25L tank Drivers

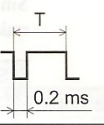
Signal	Terminal	Signal name	Description
Input	IN0 IN1 IN2 IN3 IN4	FWD	The motor rotates when either of the FWD input or REV input is turned ON. If the FWD input and REV input are turned ON simultaneously, the motor stops instantaneously.
		REV	
		M0	These signals are used to select the operation data number.
		M1	If both signals are turned OFF, the operation data No.0 is selected.
		ALARM-RESET	This signal is used to reset the present alarm when a protective function was activated. Refer to p.34 for timing chart.
		EXT-ERROR	When turning this signal OFF, an alarm generates and the motor stops instantaneously. Then "ALBE" will be shown on the display (normally closed).
		H-FREE	The slight position-keeping is released when the H-FREE input is turned ON. (When the slight position-keeping selection is set to "Enable")
Output	OUT0 OUT1	ALARM-OUT1	This signal is output when an alarm generates (normally closed).
		SPEED-OUT	30 pulses are output with each revolution of the motor output shaft synchronously with the motor operation. The pulse width of output pulse signals is 0.2 ms. You can use the SPEED-OUT output to calculate the motor speed. $\text{SPEED-OUT output frequency (Hz)} = \frac{1}{T}$ $\text{Rotation speed (r/min)} = \frac{\text{SPEED-OUT output frequency}}{30} \times 60$ 
		ALARM-OUT2	This signal is output when exceeding the overload warning level. Or this signal is output when an overload alarm generates (normally closed).
		MOVE	This signal is output while the motor is operating.
		VA	This signal is output when the motor rotation speed becomes equal the value set by the rotation speed attainment band parameter.
		WNG	This signal is output when a warning generates. (The motor will continue to operate.) When the warning is released, it will automatically turn OFF.

Note

- Do not assign the same input signal to multiple input signal terminals. When the same input signal is assigned to multiple input terminals, the function will be executed if any of the terminals become active.

k. Items displayed on the driver

Operation mode: Monitor mode

Item	Display	Description
Rotation speed *		<ul style="list-style-type: none"> Monitors the rotation speed of the motor. Monitors the rotation speed of the gear output shaft or conveyor transfer speed when the "speed reduction ratio" parameter is set. When the "speed increasing ratio" parameter is set, the rotation speed being increased by the external mechanism is displayed.
Load factor		<p>The motor generating torque can be checked. The present load factor is displayed based on the rated torque being 100%. The load factor is displayed in 1% increment between 40% and 200%, and "L -" is displayed if the load factor is smaller than 40%.</p> <p>The display is the load factor on the motor output shaft. It is not for the gearhead output shaft. In the case of the gearhead output shaft, the permissible torque varies depending on the gear ratio of the gearhead used. Use the product so that the load does not exceed the permissible torque of the gearhead output shaft.</p> <p>When the slight position-keeping is enabled, "L H" is displayed.</p>
Operation data No.		Monitors the operation data No. currently selected.
Alarm		When an alarm generates, the alarm code is displayed. You can also reset alarms or check and clear alarm records. Refer to p.32 for alarm type.
Warning		When a warning generates, the warning code is displayed. You can also check and clear warning records. Refer to p.35 for warning type.
I/O monitor		<p>You can check the ON/OFF status of each I/O signal of the driver. If the signal is ON, the corresponding digit is lit. If the signal is OFF, the digit is unlit.</p>

* For the factory setting, the rotation speed is displayed when the power is turned on. The display for when turning on the power can be changed using the parameter.

l. Display of the rotation speed

In the case of motors with the **JH** gearhead, the **JB** gearhead, and the **JV** gearhead, use the actual gear ratio about the gear ratio of gearhead. Check the operating manual supplied with the motor for the actual gear ratio.

Displayed digit number when setting the speed reduction ratio or speed increasing ratio

Since the number of significant figures for the integer part is changed if the speed reduction ratio or speed increasing ratio is set, the digit number displayed on the panel will also be changed.

Setting value for the speed reduction ratio and speed increasing ratio	Display digit on the monitor mode
1.00 to 9.99	0 to 9999
10.00 to 99.99	0.0 to 999.9
100.0 to 999.9	0.00 to 99.99
1000 or more	0.000 to 9.999

m. Display while an alarm generates

The alarm code is displayed while the alarm generates and the screen can be changed to other screens by pressing the MODE key or FUNCTION key. However, even if the screen moved from the alarm code screen to others, the alarm code display blinks so that the alarm state can be checked.

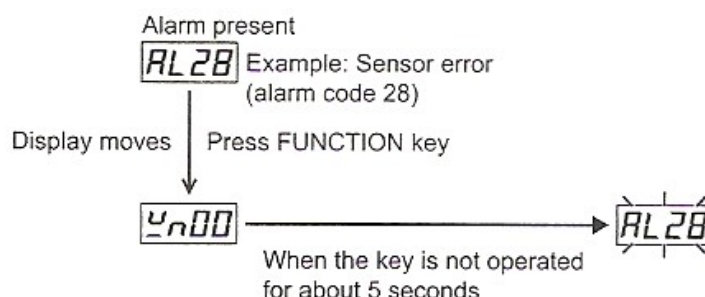

n. Setting the operation data

Four types of operation data can be set in this product. Operate by selecting the operation data number using M0 and M1 input signals.

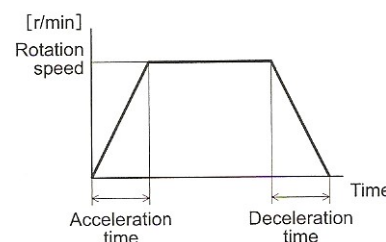

Operation mode: Data mode

Item	Display	Setting range	Factory setting	
Operation data No.0 No.1 No.2 No.3	Rotation speed	rEu	50 to 4000 r/min	50
	Acceleration time	tA	0.0 to 15.0 sec	0.5
	Deceleration time	tD		
	Initialization	ini	Restores the operation data to the factory setting. Initializes each operation data number.	-

o. Setting the acceleration time and deceleration time

The acceleration time and deceleration time can be set so that an impact is not applied to a load when the motor is started or stopped. There are the following two methods to set. The setting by the “acceleration/deceleration time potentiometer” is enabled at the time of shipment.

p. Setting using the acceleration/deceleration time potentiometer (factory setting)

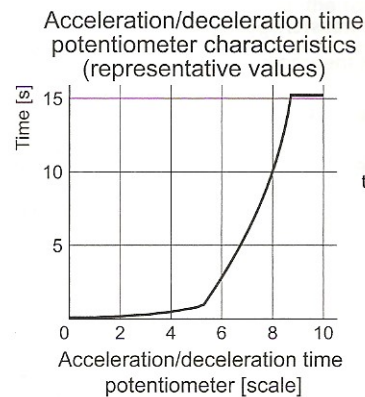
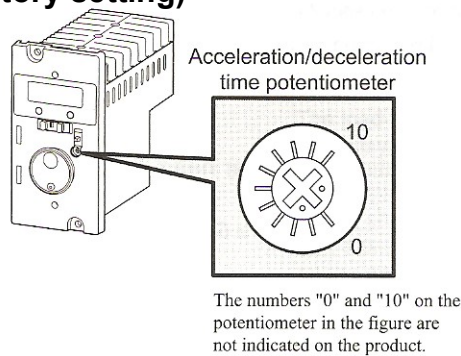

Setting range: 0.1 to 15.0 sec (factory setting: 0.1 sec)

- **Acceleration time**

The acceleration time

The acceleration time is set as time needed for the motor to reach the rated rotation speed (3000rpm) from the standstill state.

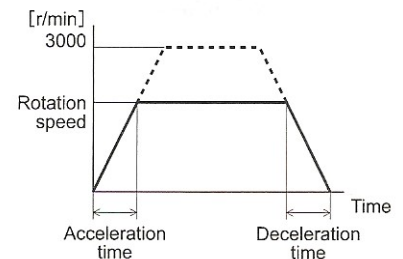

- **Deceleration time**

The deceleration time is set as the time needed for the motor to stop from the rated rotation speed (3000rpm).

q. Setting to the operation data with digital setting

When setting by the acceleration time and deceleration time of the data mode, set the “analogue acceleration/deceleration time” parameter of the parameter mode to the digital setting, \set the time needed to reach the set rotation speed.

Setting range: 0.1 to 15.0 sec (factory setting 0.5 sec)

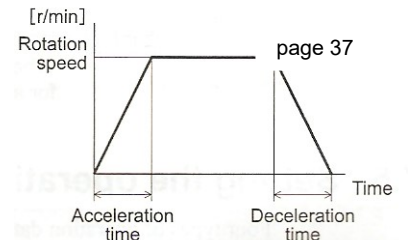

r. Motor operation

If the acceleration time and deceleration time are set shorter than 0.5 seconds, the motor takes for a longer time than 0.5 seconds to reach the speed.

If they are set to approximately 0.5 seconds or more, the motor can accelerate and decelerate in the setting time. (With no load)

When the frictional load or load inertia is increased, the operating time to reach the setting will be longer.

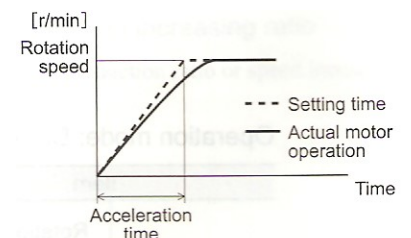

s. Data locking for the set data

The data setting can be locked so that the set rotation speed does not change. The setting of data and parameters cannot be changed using the setting dial while locking.

Remove the front panel and perform the operations shown below:

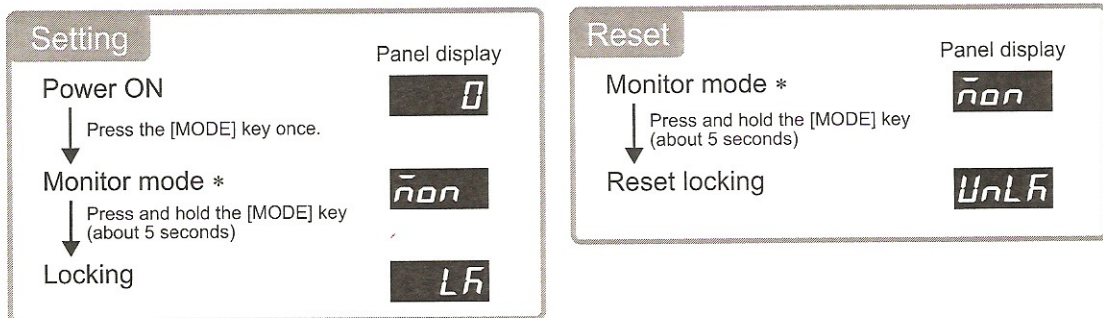
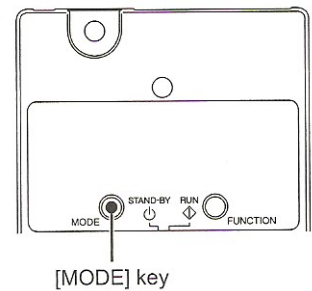

*Even when the top screen (dAtA, PAr) of the data mode or parameter mode is displayed, the data locking or reset locking can be performed.

- Display for when the edit lock function is enabled

If the setting value of the operation data or parameter is tried to change, "L6" is displayed for about one second.

t. Limiting the setting range of the rotation speed

The setting range of the rotation speed is set to 50 to 4000rpm at the time of shipment. This setting range can be changed to limit.

Setting range of the rotation speed

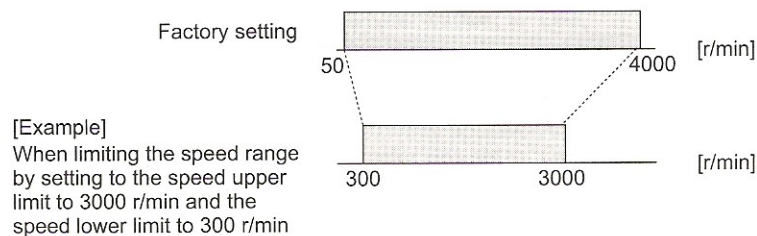

- Speed upper limit

Set the upper limit value of the rotation speed in the “speed upper limit” of the “speed upper and lower limit” parameter.

The rotation speed exceeding the “speed upper limit” cannot be set in the rotation speed of the operation data.

If the rotation speed exceeding the “speed upper limit” is already set in the operation data, the rotation speed set in the “speed upper limit” will be overwritten.

- Speed lower limit

Set the lower limit value of the rotation speed in the “speed lower limit” of the “speed upper and lower limit” parameter.

The rotation speed lower than the “speed lower limit” cannot be set in the rotation speed of the operation data.

If the rotation speed lower than the “speed lower limit” is already set in the operation data, the rotation speed set in the “speed lower limit” will be overwritten.

**If you have any questions,
please contact us for assistance.**

E-mail technical@sr-tek.com

Setup

a. Reservoir

1. Install the air tubing into the reservoir regulator already installed on the reservoir lid. Maximum pressure is 60psi (4bar). If no air filter regulator is available, please install one.
2. Remove the tank cover and temporarily store it on the side. When filling or refilling the tank, use a cup (not included) to catch any excess material that drips from the feed tube.
3. Cut the fluid feed tubing to an appropriate length to go inside the tank. Cut one end of the feed tubing at an angle and push the tubing through the compression fitting and adjust the inside length so it sits just off the bottom of the tank. Tighten the compression nut to secure the tube. Stainless steel sleeve to maintain the tube in position is available as an option.
4. Attach the other end of the fluid feed tubing to the other part of your system.
5. Fill the tank either by pouring material directly into the tank or placing a plastic SR-TEK jar or a manufacturer's bottle inside the tank.
6. Install the lid. If you are using a manufacturer's bottle, ensure the feed tube is inserted into the bottle.
7. Secure the swing bolts on the lid and tighten the eye nuts securely.
8. Adjust the tank air regulator to a pressure sufficient to pressurise the material. Typical settings are 5 to 10 psi (0.3 to 0.6 bar) for low viscosity and 30 to 50 psi or (2.0 to 3.4 bar) for higher viscosity fluids.

Compatibility between the equipment described in this manual, the fluid, the usage and the application remain the responsibility of the operator. Special attention must be paid to potential risks of corrosion and abrasion forming inside the tank. If signs of corrosion or abrasion are detected, safely disconnect the equipment and remove the tank away from the working area.

If, while operating with the equipment, something unusual is noticed, immediately stop all operations involving the pressure tank and contact SR-TEK.

If the tank is not installed and connected correctly, not maintained regularly, used in a different way than its intended purpose, modified in any ways or safety instructions not followed, serious injuries to operators and staff working in close proximity can result out of it. SR-TEK cannot be held responsible for misuse of the equipment.

b. Agitator

Most agitated reservoirs are supplied fully assembled by SR-TEK. The information page 42 given below only applies when the agitator is delivered separately from the reservoir.

If you assemble the agitator yourself, it is important to make sure the mixing blade do not touch the internal wall and bottom flange of the tank when in operation. The minimum recommended distance between the blade and the bottom of the tank should be no less than 20mm.

The connection between the different elements is displayed on the exploded view present in this manual. Fastening of the different components is made with Allen Keys and adjustable spanners.

If manual assembly is required, please refer to the exploded view on page **xx** and **xx**. Once the agitation assembly has been fitted, follow the instruction in the next section **c. Driver**.

c. Driver

Install the driver in a well-ventilated place where it can be inspected easily and the following conditions are satisfied:

- Indoors
- Operating ambient temperature: 0 to 38°C
- Operating ambient humidity: 85% or less
- Area that is free of explosive atmosphere or toxic gas or liquid
- Area not exposed to direct sun
- Area free of excessive amount of dust, iron particles or the like
- Area not subject to splashing water (rain, water droplets), oil (oil droplets) or other liquids
- Area free of excessive salt
- Area not subject to continuous vibration or excessive shocks
- Area free of excessive electromagnetic noise (welders, power machinery, etc...)
- Area free of radioactive materials, magnetic fields or vacuum
- Altitude: Up to 1000m above sea level

The driver is designed so that heat is dissipated via air convection and conduction through the enclosure. There must be a clearance of at least 25mm and 50mm clearances in the horizontal and vertical directions, respectively, between the driver and enclosure or other equipment within the enclosure.

1. Install the diver so that the front panel side of the driver is turned in the front direction or upward.

If the driver is installed with the front panel side facing front, the operating ambient temperature is 0 to 38°C

If the driver is installed with the front panel side facing upward, the operating ambient temperature is 0 to 38°C.

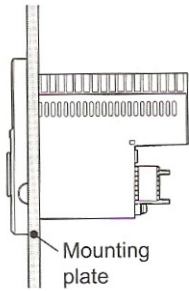
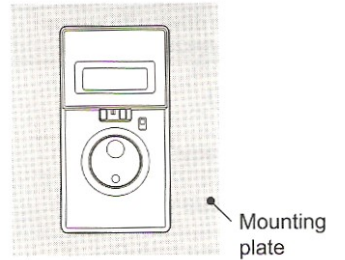

Front direction

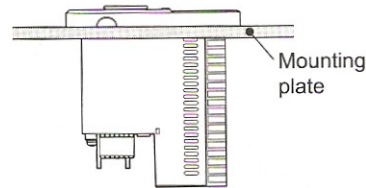

Upward Direction

- **DO NOT** install any equipment that generates a large amount of heat or noise near the driver.
- If the ambient temperature of the driver exceeds the upper limit of the operating ambient temperature, revise the ventilation condition or forcibly cool the area around the driver using a fan in order to keep within the operating ambient temperature.

**If you have any questions,
please contact us for assistance.**

E-mail technical@sr-tek.com

2. Chose an area to install the driver.

Installation location

Install the driver in a well-ventilated place where they can be inspected easily and he following conditions are satisfied:

- Indoors
- Operating ambient temperature: 0 to 38°C
- Operating ambient humidity: 85% or less
- Area that is free of explosive atmosphere or toxic gas or liquid
- Area not exposed to direct sun
- Area free of excessive amount of dust, iron particles or the like
- Area not subject to splashing water, oil or other liquids
- Area free of excessive salt
- Area not subject to continuous vibration or excessive shocks
- Area free of excessive electromagnetic noise
- Area free of radio active materials, magnetic fields or vacuum
- Maximum permitted altitude of up to 1,000m above see level

Installing the driver

The driver is designed so that heat is dissipated via air convection and conduction through the enclosure.

There must be a clearance of at least 25mm and 50mm clearances in the horizontal and vertical directions, respectively, between the driver and the enclosures or other equipment within the enclosures.

When installing the driver, mount it turning the driver front panel to the front side or upper side.

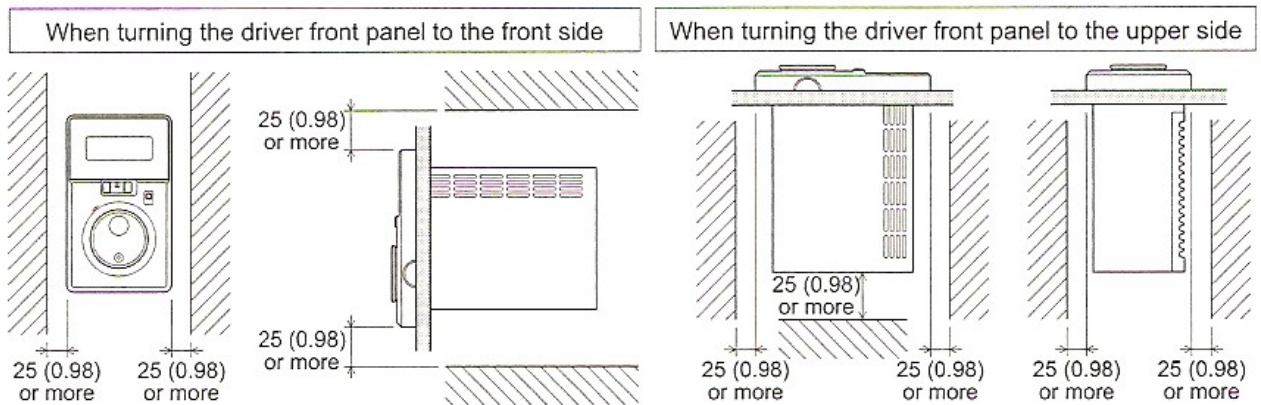

- **DO NOT** install any equipment that generates a large amount of heat or noise near the driver.
- If the ventilation condition or forcibly cool the area around the driver using a fan in order to keep within the operating ambient temperature.

There are two possible ways of installing the driver. Either directly mounted on a flat surface or using the bracket supplied with the driver.

If installing the driver to a flat metal plate. Make sure the surface offers excellent vibration resistance.

Remove the front panel of the driver and secure the two mounting holes using screws and nuts (M4 or No.8-32UNC: not supplied). Tighten the screws until no gaps remain between the driver and mounting plate.

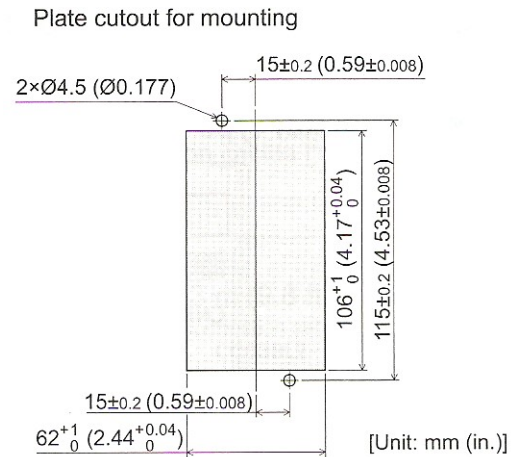
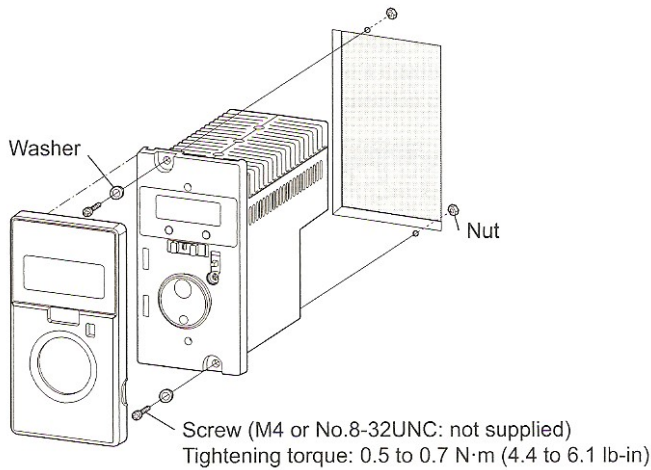

- The space between the mounting hole section and front panel of the driver is 6mm. Therefore, the total height of the screw head and washer should be less than 6mm. The front panel cannot be installed if it is exceeded 6mm.
- If the washer is used, use the washer which outer diameter is 10mm or less.

[Removing and installing the front panel]

Installing

Install the front panel after placing on the upper side of the driver front face.

Removing

Remove the front panel having the under side.

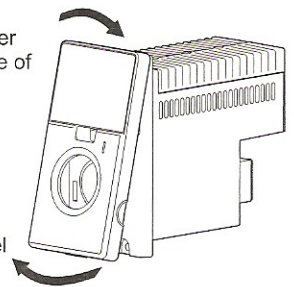

d. Connecting the motor and driver

Connect the motor connector (white) of the connection cable to the CN2, and the sensor connector (black) to the CN3 on the driver.

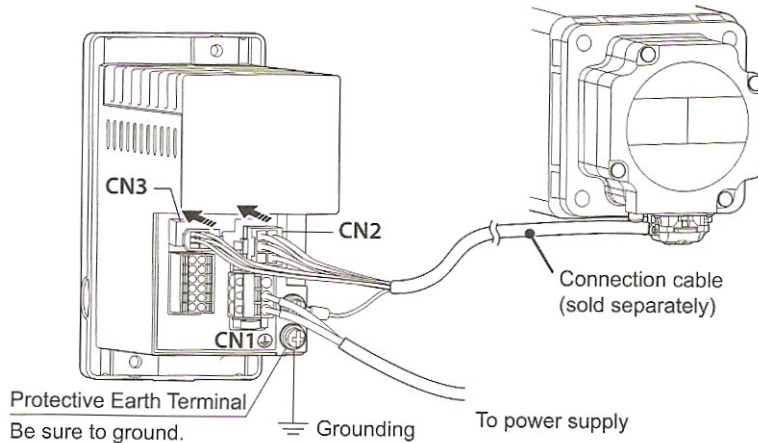

Connect the dedicated connection cable (included) to the motor and driver. The connection cables are provided up to 10m. Standard cable supplied is 1m.

Connect the dedicated connection cable (sold separately) to the motor and driver. The connection cables are provided up to 10 m (32.8 ft.).

[Cable leading direction]

Leading in direction of output shaft

Leading in opposite direction of output shaft

1 Remove

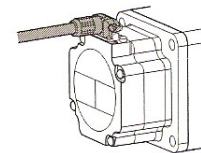
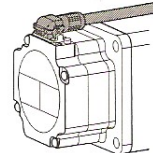
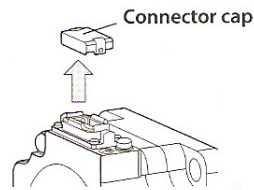

2 Attach

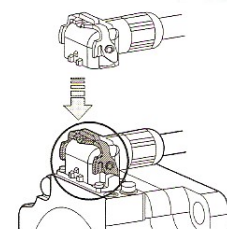

Position of lever

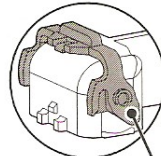

Locking lever

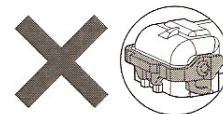

The connector cannot be inserted if the locking lever is turned down.

3 Secure

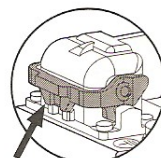
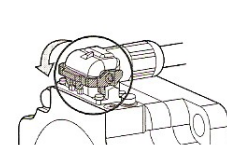

Be sure to turn down the locking lever till the position shown in the figure.

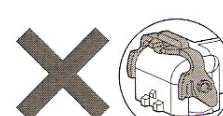

The connector cannot be secured unless the locking lever is turned down.

DO NOT Carry the tank nor the driver by the cable. Doing so may cause damage to the product.

To remove the connection cable, turn up the locking lever.

Use a connection cable for relay when extending the wiring distance between the motor and the driver.

The connection cable for relay can be used by connecting up to two pieces. The wiring distance between the motor and the driver can be extended to a maximum of 10.5m.

Contact SR-TEK for additional cable and if connection to relay is required.

Below is an example of extension by adding two connection cables.

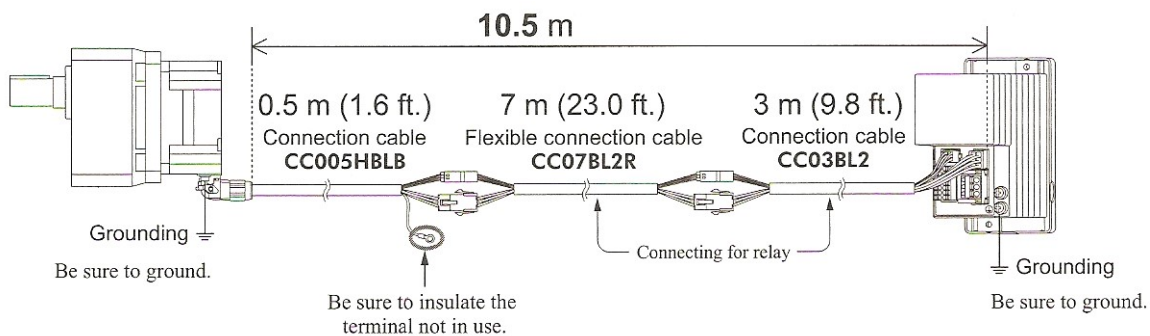

- Secure each connectors part not to apply stress on the connector's part. If not secured, the cables may get damaged by the stress.
- Securely insert the connector straight. Unsecured connections may cause malfunction or damage to the motor or driver.

**If you have any questions,
please contact us for assistance.**

E-mail technical@sr-tek.com

e. Grounding

Note: Be sure to ground the motor and driver. Failure to do so may result in electric shock or damage to the product. Static electricity may cause damage to the product if the Protective Earth Terminals are not grounded.

Ground using the Protective Earth Terminals (⏚) of the motor and driver, as well as the ground terminal of the connection cable.

Connect the ground terminal of the connection cable to the driver as shown in the figure 1.

However, the grounding resistance value provided in the standards that is applied to the equipment may not be satisfied depending on the type of length of the connection cable.

In the case, ground near the motor using the Protective Earth Terminal (⏚) on the motor.

If the ground terminal of the connection cable is not used, be sure to insulate.

For the driver, ground near the driver using the Protective Earth Terminal (⏚).

Do not share the Protective Earth Terminal with a welder or any other power equipment.

Reference 1, 2, and 5L

Protective earth wire of the connection cable

Conductor size: AWG18 (0.75mm²)

Maximum conductor resistance: 25.0 Ω/km

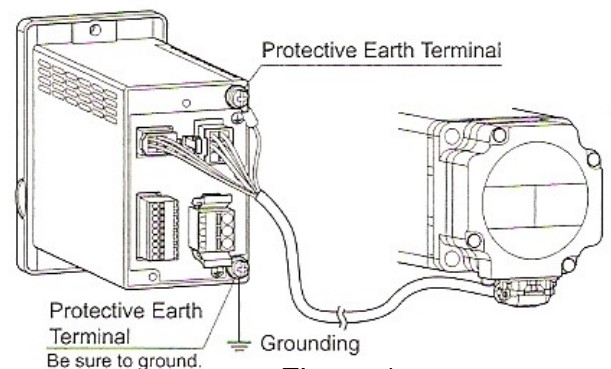

Figure 1

Cable type for driver supplied with tank

Be sure to ground using the Protective Earth Terminal (⏚) of the driver.

Two Protective Earth Terminals (⏚) are provided on the driver. Ground either of the two Protective Earth Terminals near the driver.

The terminal that is not grounded is used as a service terminal.

Use the service terminal according to your specific need, such as connecting it to the motor

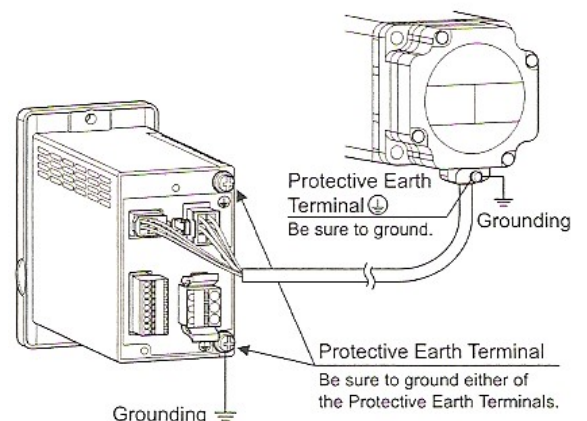

in order to ground the motor.
Do not share the Protective Earth Terminal with a welder or any other power equipment.

f. Connecting to Protective Earth Terminal

To connect to the Protective Earth Terminal, ground using the following grounding terminal. Ground as a short distance as possible.

Ground Terminal

Applicable crimp terminal:
Round crimp terminal with insulation cover
Thread size of terminal: M4
Tightening torque: 1.2Nm
Applicable lead wire: AWG18 to 14

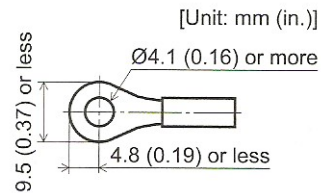

- Static electricity may cause the driver to malfunction or suffer damages.
- Be sure to ground the motor and the driver to prevent from being damaged by static electricity.

g. Connecting the power supply

Connect the power cable to the CN1 on the driver.
The power cable is not included. It is provided as an accessory.

Single-phase 200-240 V

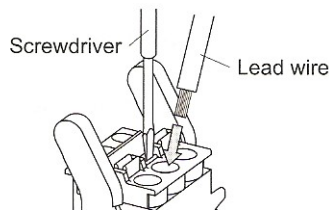
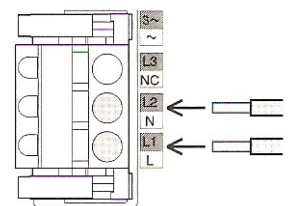

- Lead wire size: AWG18 to 14 (0.75 to 2.0 mm²)
- Length of the insulation cover which can be peeled: 10 mm (0.39 in.)
- Conductive material: Use only copper wire.

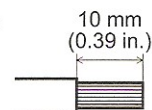

Be sure to connect a circuit breaker to the power line of the driver to protect the primary circuit.
Rated current of protective device: Single-phase input 10A, three-phase input 10A.

Recommended circuit breaker: Mitsubishi Electric Corporation NF30

Connecting the I/O signals on the Driver

Connect the I/O signals to CN4 on the driver.

Connecting the lead wire

- Applicable lead wire: AWG26 to 20 (0.14 to 0.5mm³)
- Length of the insulation cover which can be peeled: 8mm

CN4 Pin assignment

Pin No.	Terminal	Function *	Description
9	C0	Input signal common (For external power supply)	Connect when using the external power supply.
8	X0	[FWD]	The motor rotates in the forward direction while this signal is being "ON."
7	X1	[REV]	The motor rotates in the reverse direction while this signal is being "ON."
6	X2	[M0]	This signal is used to select the operation data.
5	C1	0 V (For internal power supply)	Connect when using the built-in power supply.
4	Y0+	[SPEED-OUT]	30 pulses are output with each revolution of the motor output shaft.
3	Y0-		
2	Y1+	[ALARM-OUT1]	This signal turns OFF when an alarm generates (normally closed).
1	Y1-		

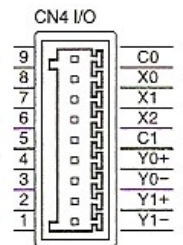

The signal in brackets [] is a function that is assigned at the time of shipment. The assigned functions can be changed by setting parameters. Refer to page ... for details.

Input Signal circuit

All input signals of the driver are photocoupler inputs. Use these signals by the internal power supply (+5VDC) or external power supply.

When using the external power supply, both sink input logic and source input logic can be used by changing the wiring.

Usable external power supply: 24VDC – 15% to +20%, 100mA or more.

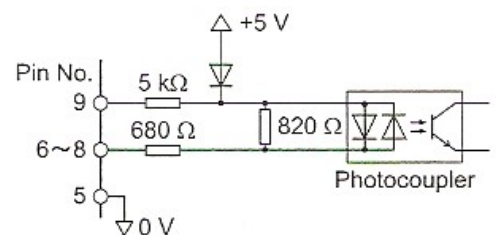

Output signal circuit

The driver outputs signals are photocoupler/collector output.

When driving each element using the output signal circuit, give consideration to this ON voltage.

ON voltage: 1.5VDC maximum

External power supply: 4.5 to 30VDC, 100mA or less (5mA or more for the SPEED-OUT output).

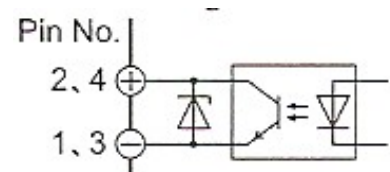

When connecting a relay (inductive load), etc...to detect alarm outputs, use a relay with built-in flywheel diode, or provide a fly-back voltage control measure based on diode, etc...for the inductive load.

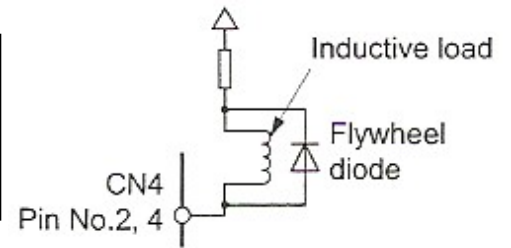

Using an external control equipment with a built-in clamp diode

If an external control equipment with a built-in clamp diode is used, a leakage path may form and cause the motor to operate even when the external control equipment power is off, as long as the driver power is ON. Since the power capacity of the controller is different from that of the driver, the motor may operate when the external control equipment and driver powers are turned on or off simultaneously.

When powering down, turn off the driver power first, followed by the external control equipment power.

When powering up, turn on the external equipment power first, followed by the driver power.

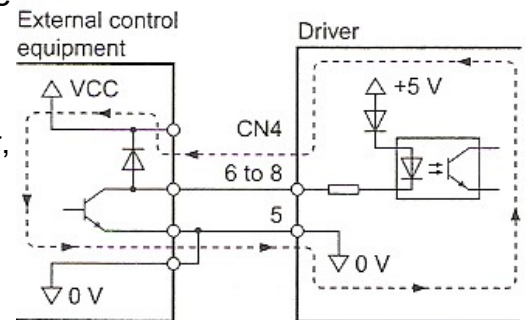

The following diagram is an example when the motor is operated using contact switches such as switches and relays for driver supplied with 1, 2 and 5L.

The connection example is for single-phase input. The power supply connection for the three-phase input is different. Contact SR-TEK for more information.

Sink logic

When using the built-in power supply is used for input signals.

The I/o signal in the brackets [] is the assignment at the time of shipment.

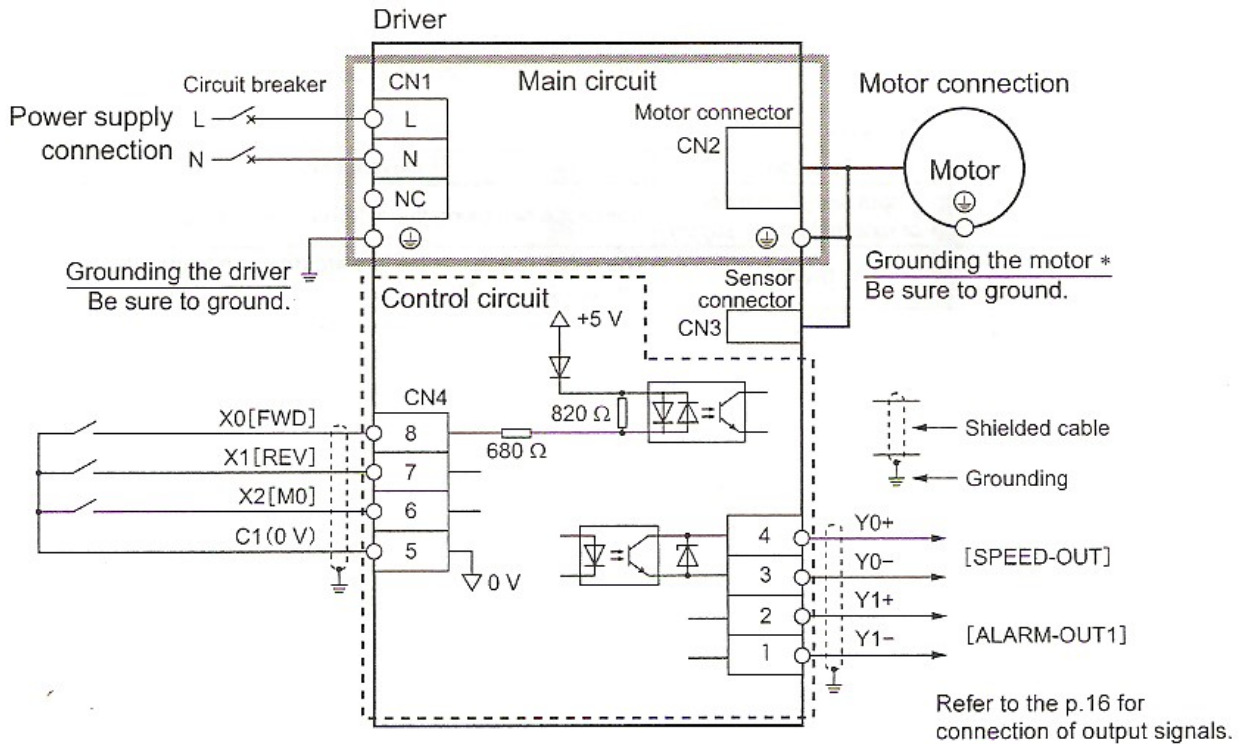

When using the external power supply

This is a connection example for when the external power supply is used for input signals.

The I/O signal in the brackets [] is the assignment at the time of shipment.

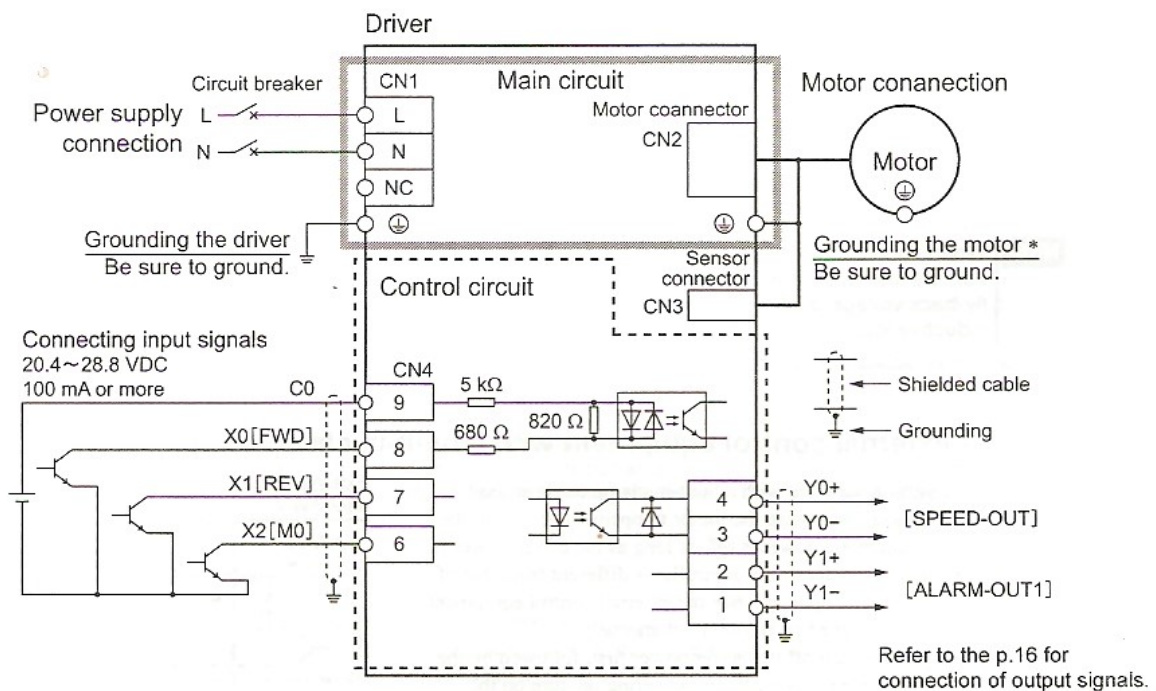

Source logic

When using the external power supply.

This is a connection example for when the external power supply is used for input signals.

The I/O signal in the brackets [] is the assignment at the time of the shipment.

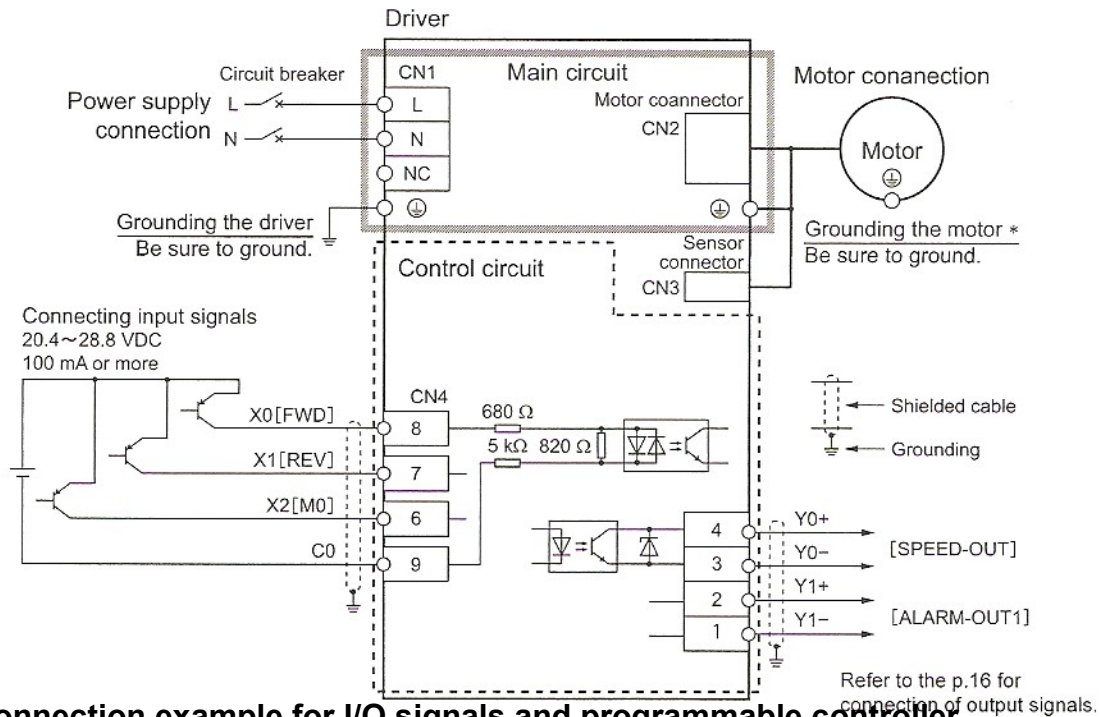

Connection example for I/O signals and programmable controller

This is a connection example when the motor is operated using a transistor output type programmable controller.

Sink logic

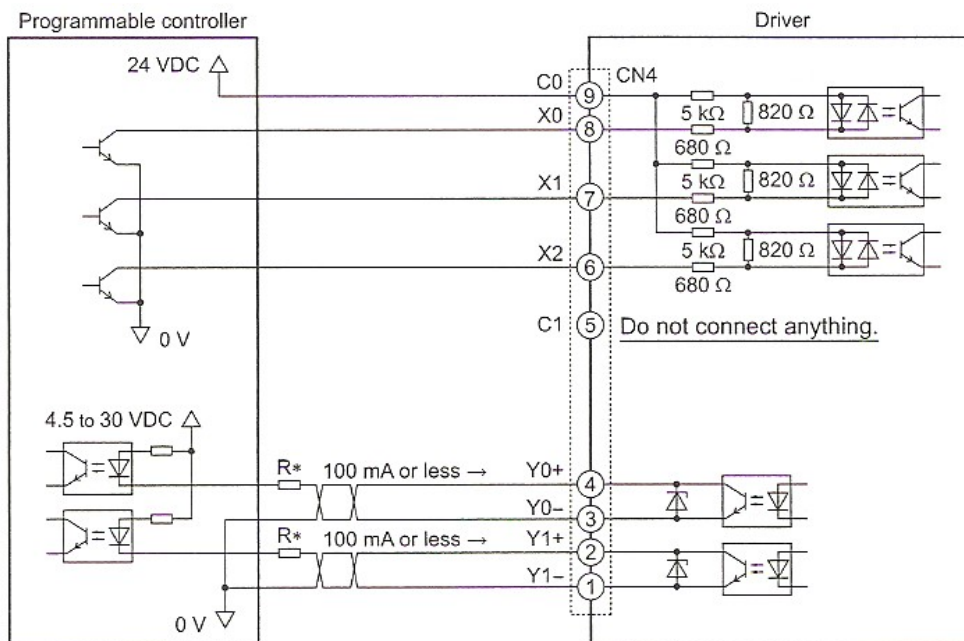

Recommended resistance value for when the limiting resistor R is connected

In the case of 24VDC: 680 Ω to 2.7 kΩ (2 W)

In the case of 5 VDC: 150 Ω to 560 Ω (0.5 W)

Source logic

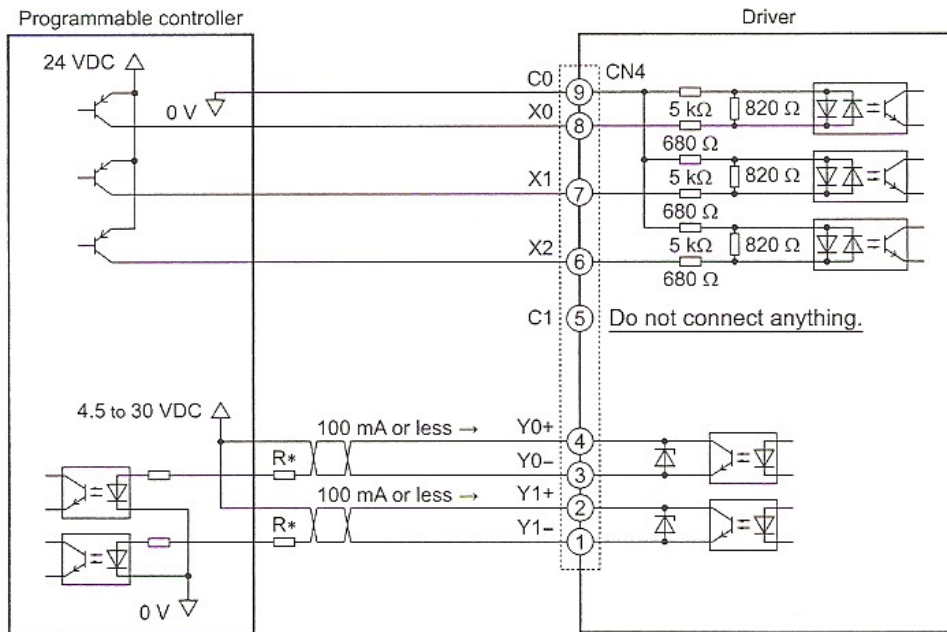

Recommended resistance value for when the limiting resistor R is connected
 In the case of 24VDC: 680 Ω to 2.7 kΩ (2 W)

In the case of 5 VDC: 150 Ω to 560 Ω (0.5 W)

- Use a power supply of 20.4VDC to 28.8VDC, 100mA or more, for connecting input signals.
- Turn on the external power supply before turning on the main power supply of the driver.
- For the Y0 and Y1, be sure to keep the current value at 100mA or less. If the current exceeds this value, connect the limiting resistor R.
- Do not connect anything to the pin No. 5 when the external power supply is used.

**If you have any questions,
 please contact us for assistance.**

 E-mail technical@sr-tek.com

Pressure Relief Procedure

To reduce the risk of body injury, including fluid splashing into the eyes, **NEVER** attempt to open the reservoir without first performing this procedure.

1. Turn pressure to 0 on the reservoir air regulator.
2. Actuate the air relief valve. Hold the relief valve open until any hissing sounds end.
3. Confirm that the indicated gauge pressure is zero.
If the gauge reads zero, slowly release the cover clamps and remove the cover.
4. If the pressure gauge does not read zero after performing Steps 1 and 2, remove the air input hose from the air regulator and set the regulator pressure to zero. A hissing sound should be heard from the regulator during this step. Once the gauge reads zero, return to Step 3. Do not use the reservoir until the air relief valve is replaced.

Refilling

To open the tank, follow the Pressure Relief Procedure above.
Follow setup steps 1-8 to refill, make sure the air pressure is off or disconnected from the air motor.

Note: When pressurised, it is normal to hear a hissing sound coming from the regulator. This is due to the constant-bleed regulator feature.

Wetted Parts List

The following materials come in contact with the fluid during normal use:

1. Polyethylene (fluid feed tubing)
2. For all CT models: Stainless steel grade 303 and Acrylic cylinder
For all CTG models: Stainless steel grade 303 and Toughened glass cylinder
3. For all CTEL models stainless steel grade 303 and 316 mixing shaft and blade.
4. Optional polyethylene jar

Troubleshooting

Maintenance and repair work may be carried out only on a tank which has been completely depressurised and fully disconnected from fluid, air and power lines.

Trouble:	Cannot set or maintain reservoir pressure
-----------------	--

Possible Cause	Solution
-----------------------	-----------------

- | | |
|---|--|
| ➤ star grips not secured | Make sure all-star grips are secured hand-tight. |
| ➤ Leaking feed tube compression fitting | Make sure compression fitting is assembled per instructions. If leak continues after proper installation, replace with new fitting. |
| ➤ Damaged lid O-ring seal | Replace damaged O-ring seal. |
| ➤ Damaged/malfunctioning air relief valve | Replace with new air relief valve. |
| ➤ Kinked air supply line | Make sure air supply line is straight and protected from other equipment. |
| ➤ Lid seal surface dirty or damaged | Clean both the tank's flange and the lid
Do not use sharp or pointy tools.
Make sure cover sealing surface is free from debris or other contamination.
The reservoir or the lid should be replaced if there is a cut or gouge in the sealing surface deep enough to prevent the tank from achieving its set pressure. |
| ➤ Damaged/malfunctioning air regulator | Replace with new air regulator. |
| ➤ Damaged/malfunctioning Pressure gauge | Replace with new pressure gauge. |
| ➤ Air supply is fluctuating | Supply system regulator is required.
Set the regulator to the lowest plant air fluctuation. |

Trouble:	Air leak from agitator
-----------------	-------------------------------

Possible Cause	Solution
-----------------------	-----------------

- | | |
|-----------------------------|---|
| ➤ Motor not sealed properly | Check sealing motor and mounting studs. If leak continues after changing O-ring, replace motor. |
|-----------------------------|---|

Trouble:	Bad quality mix or no agitation
-----------------	--

Possible Cause	Solution
-----------------------	-----------------

- | | |
|--|---|
| ➤ Slipping shaft, shaft coupling or mixing blade | Make sure the shaft, shaft coupling and mixing blade a tightened properly. |
| ➤ Power to the Motor or the controller | Check the power to the motor and the controller. Check the display on the controller. If the power is on and the motor does not Rotate, contact SR-TEK. |
| ➤ Alarm & Warnings | Check the display of the controller for alarms or warning. Consult page 58 for a full alarms and warnings list. |
| ➤ High viscosity fluid | Check compatibility between equipment and fluid viscosity. |

Trouble:	Vibration during operation
-----------------	-----------------------------------

Possible Cause	Solution
-----------------------	-----------------

- | | |
|------------------------|--|
| ➤ High viscosity fluid | Check compatibility between equipment and fluid viscosity. |
| ➤ Bent shaft | Check shaft alignment. Replace shaft. |
| ➤ Loose coupling | Check shaft coupling tightness. |
| ➤ Faulty bearing | Contact SR-TEK to replace the motor. |

Trouble:	Overheating motor
-----------------	--------------------------

Possible Cause	Solution
-----------------------	-----------------

- | | |
|-----------------------|---|
| ➤ Motor is overloaded | Check compatibility between equipment and fluid viscosity. Upgrade the motor or change mixing blade design. |
|-----------------------|---|

Trouble:	The motor does not operate
-----------------	-----------------------------------

Possible Cause	Solution
-----------------------	-----------------

- | | |
|---|--|
| ➤ The power supply is not Connected correctly or it Has become improper Connection. | Check the connections between the driver and the power supply. |
| ➤ The operation switch is Set to the "STAND-BY" Side. | Set the operation switch to the "RUN" side. |
| ➤ When operating the motor using the operation switch, the "external operation signal input" parameter is set to "ON" or "RE" | Set the "external operation signal input" parameter to "OFF" after setting the operation switch to the STAND-BY side. |
| ➤ When operating the motor using external signals, the "external operation signal input" parameter is set to "OFF" | Set the "external operation signal input" parameter to "ON" or "RE" after turning the input operation signal OFF. |
| ➤ Both the FWD and REV input are being OFF or ON. | Turn either of the FWD input or REV input ON. |
| ➤ An alarm is present. | A protective function is triggered and an Alarm generates. Refer to page 59 and Reset the alarm after removing the cause of the alarm. |





Trouble:	The rotation speed is not displayed
-----------------	--

Possible Cause	Solution
-----------------------	-----------------

- | | |
|--|---|
|  The “panel initial view” Parameter is not set to The rotation speed. | Set the “panel initial view” parameter to the rotation speed. |
|--|---|

Trouble:	The motor rotates in the opposite direction than the one specified
-----------------	---

Possible Cause	Solution
-----------------------	-----------------

- | | |
|---|---|
|  The FWD input and REV input are connected wrongly otherwise not connected correctly. | Check the connection of the FWD input and REV input. |
|  The gear ratio that the gearhead output shaft rotates in the opposite direction against the motor rotation direction is used. | Check the operating manual supplied with the motor for the rotation direction of the gearhead output shaft. |
|  The rotation direction Switch is set wrong. | Check the rotation direction switch. |
|  When the rotation Direction switch is set To REV, the “external operation signal input” parameter is set to “RE” | Check the setting of the “external operation signal input” parameter. |

Trouble:	The setting cannot be performed using the setting dial
-----------------	---

Possible Cause	Solution
-----------------------	-----------------

- | | |
|---|-----------------------|
|  The lock function has been enabled. | Release the function. |
|---|-----------------------|

Trouble:	The set rotation speed is not saved.
-----------------	---

Possible Cause	Solution
-----------------------	-----------------

- | | |
|--|--|
|  It is not determined by pressing the setting dial. | After setting the rotation speed, determine it by pressing the setting dial. |
|--|--|

Trouble:	The motor does not reverse by the rotation direction switch
-----------------	--

Possible Cause	Solution
-----------------------	-----------------

- | | | |
|---|---|---|
| ➤ | The “external operation signal input” parameter is set to “RE”. | Check the setting of the “external operation signal input” parameter. |
|---|---|---|

Trouble:	The rotation speed cannot be increased or decreased
-----------------	--

Possible Cause	Solution
-----------------------	-----------------

- | | | |
|---|-------------------------------------|------------------------------|
| ➤ | The speed upper limit has been set. | Raise the speed upper limit. |
| ➤ | The speed lower limit has been set. | Lower the speed lower limit. |

Trouble:	Motor operation is unstable or motor vibration is too great
-----------------	--

Possible Cause	Solution
-----------------------	-----------------

- | | | |
|---|--|---|
| ➤ | The motor and the gearhead output shaft is misaligned with the load shaft. | Check the coupling condition of the motor and gearhead output shaft and the load shaft. |
| ➤ | Effect of electrical noise. | Check the operation only with the motor, Driver and other external equipment Required for operation.
If an effect of noise has been confirmed, Implement the following countermeasures:
- move the unit further away from noise generation sources.
- review the wiring
- change the signal cables to a shielded type
- Install ferrite cores. |

Alarms and warnings

The driver provides alarms that are designed to protect the driver from overheating, poor connection, error in operation, etc...(protective functions), as well as warnings that are output before the corresponding alarms generate (warning functions).

If a positive function is activated and an alarm is generated, the motor will coast to a stop, and then the holding power of the motor output shaft is lost. At the same time, the alarm code is displayed. The alarm type can be checked by the alarm code.

- Cycle the power to reset the overcurrent and EEPROM error alarms. When cycling the power, turn off the power and wait for minimum 1 minute before doing so. If the motor or controller does not operate properly after the power is cycled, the internal circuit may be damaged. Contact SR-TEK.
- The motor stops instantaneously at the time of the external stop (AL6E). After the motor is stopped, the holding power of the motor output is lost.

See list of alarms on the next page.

Alarm list

Alarm code	Alarm type	Cause	Remedial action	Alarm reset *1
AL20	Overcurrent	Excessive current has flown through the driver due to ground fault, etc.	Check the wiring between the driver and motor for damage.	Not possible
AL21	Main circuit overheat	The temperature inside the driver exceeded the alarm detection temperature.	<ul style="list-style-type: none"> Review the ambient temperature. Review the ventilation condition in the enclosure. 	Possible
AL22	Overvoltage	<ul style="list-style-type: none"> The power supply voltage exceeded approximately 120% of the rated voltage. Vertical drive (gravitational operation) was performed or a load exceeding the permissible load inertia was driven. 	<ul style="list-style-type: none"> Check the power supply voltage. If this alarm occurs during operation, reduce the load or make the acceleration/deceleration time longer. 	
AL25	Undervoltage	The power supply voltage became lower than approximately 60% of the rated voltage.	<ul style="list-style-type: none"> Check the power supply voltage. Check the wiring of the power supply cable. 	
AL28	Sensor error	During operation, the sensor signal line of the motor cable or connection cable was disconnected, or the sensor connector came off.	Check the wiring between the driver and motor.	Possible
AL30	Overload	<ul style="list-style-type: none"> A load exceeding the continuous duty region was applied to the motor for the time exceeded the value set in the "overload alarm detection time except when holding a shaft" parameter. Or the output shaft was locked. *2 The motor was started running under the state that the motor temperature was low. 	<ul style="list-style-type: none"> Reduce the load. Review the operation pattern such as acceleration/deceleration time. If the ambient temperature is low, perform a trial operation in a light load state. 	
AL31	Overspeed	The rotation speed of the motor output shaft exceeded approximately 4800 r/min.	<ul style="list-style-type: none"> Reduce the load. Review the operation pattern such as acceleration/deceleration time. 	
AL41	EEPROM error	<ul style="list-style-type: none"> The stored data was damaged. Data became no longer writable or readable. 	Initialize the parameters.	Not possible
AL42	Sensor error at power-on	Before the power supply is turned on, the sensor signal line of the motor cable or connection cable was disconnected, or the sensor connector came off.	Check the wiring between the driver and motor.	Possible
AL45	Prevention of operation at power-on *3	When the "external operation signal input" parameter was set to "OFF," while the operation switch was set to the "RUN" side, the power was turned on again.	Set the operation switch to the "STAND-BY" side from the "RUN" side.	
		When the "external operation signal input" parameter was set to "ON," while the FWD input or REV input was turned ON, the power was turned on again.	<ul style="list-style-type: none"> Set the operation switch to the "STAND-BY" side from the "RUN" side. Turn the FWD input or REV input from ON to OFF. 	
AL5E	External stop *4	The EXT-ERROR input turned OFF.	Check the EXT-ERROR input.	

- *1 When using the alarm reset on the monitor mode or resetting the alarm by assigning the ALARM-RESET input to the input to the terminal
- *2 If a load exceeding the limited duty region was applied or the output shaft was locked, an alarm is generated in maximum 5 seconds. However, if the value of the "overload alarm detection time except when holding a shaft" parameter is set to 5 seconds or less, the overload alarm is generated in the time that was set.
- *3 This alarm is output when the "prevention of operation at power-on alarm" parameter is set to "Enable". Refer to page *parameter list* for setting whether to enable or disable the "prevention of operation at power-on alarm" parameter.
- *4 This alarm is output when the EXT-ERROR is assigned to input terminal.

Alarm reset

Always reset an alarm after ensuring safety by removing the cause of the alarm and turning the operation signal OFF.

[How to reset the alarm]

- Turn the ALARM-RESET input to ON and then OFF. (The alarm will be reset at the OFF edge of the input.)
- Perform an alarm reset with the monitor mode.
- Turn off the power, wait for at least 1 minute, and then cycle the power.

When an alarm is reset, "AL00" is displayed for two seconds, then "0" * is displayed. (Except for cycling the power)

* The screen selected in the "panel initial view" parameter is displayed.

- If the motor does not operate properly after the power is cycled, internal circuit damage is suspected. Please contact SR-TEK.
- Continuing the operation without removing the cause of the problem may cause malfunction of the equipment.

Reset using the ALARM-RESET input

Turn the operation signal OFF and then turn ALARM-RESET input ON (keep it ON for 10msec or more).

The ALARM-RESET input is disabled while the operation signal is being on. The figure shows an example for which the operation signal is the FWD input.

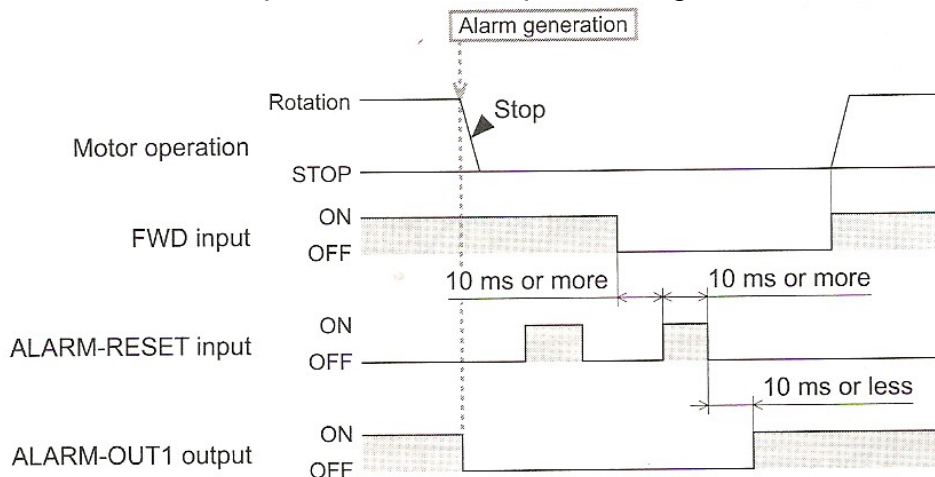

Reset with the monitor mode

Set the operation switch to the “STAND-BY” side from the “RUN” side, and reset the alarm by the following steps.

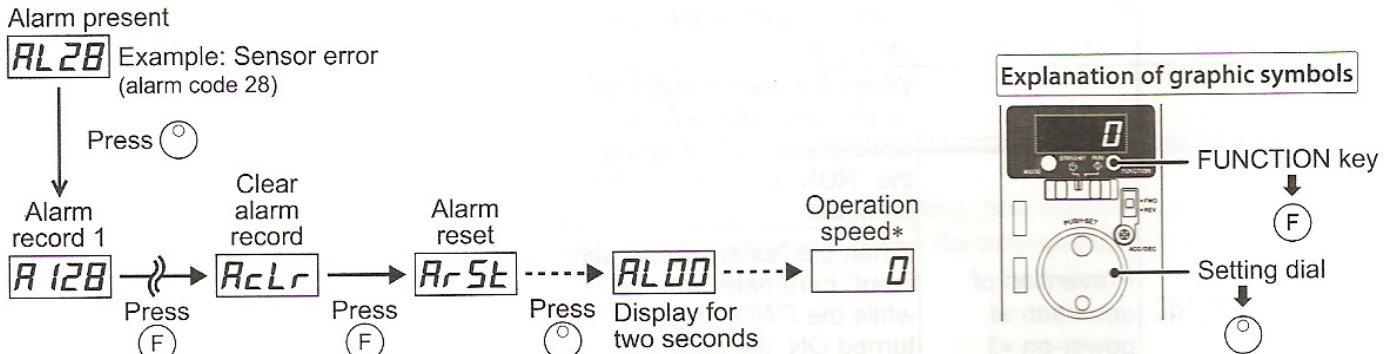

* The screen selected in the “panel initial view” parameter is displayed.

When the present alarm is the prevention of operation at power-on alarm “AL46”

When operating the motor using the front panel, change the setting of the operation switch from the RUN side to the STAND-BY side.

When operating the motor using external input signals, the alarm will be reset by turning the operation signal OFF. This is the factory setting. The method to reset the alarm can be changed Refer to page 59 for details.

Alarm records

Up to 9 generated alarms are saved in the non-volatile memory in order of the latest to oldest.

When clearing the alarm records, perform the alarm record clear on the monitor mode.

- Do not turn off the driver power while an alarm records are being cleared (=while the display is blinking). Doing so may damage the data.

Warnings

The warning types and records can be displayed on the monitor mode.

When a warning generates, the WNG output will be turned ON. The WNG output is not assigned to the output terminal at the time of shipment. Refer to page 59 “Description of I/O signals”.

Warning List

Warning code	Warning type	Motor operation	Generation condition	Remedial action
U _{n21}	Main circuit overheat	Continue to operate	The temperature inside the driver exceeded the warning detection temperature.	<ul style="list-style-type: none">• Review the ambient temperature.• Review the ventilation condition in the enclosure.
U _{n30}	Overload		A load exceeding the "overload warning level" parameter was applied to the motor.	Check the load condition.
U _{n5c}	Operation error	Stop	When the input terminal is ON, the operation signal was assigned using the "input function selection" parameter.	When assigning the operation signal, check that the input terminal to be assigned is turned OFF.

Warning records

Up to 9 generated warnings are saved in the RAM in order of the latest to the oldest. When clearing the warning records, perform the warning record clear on the monitor mode.

- The warning records will be cleared by turning off the driver power.

Precautions about static electricity

Static electricity may cause the driver to malfunction or suffer damaged.

Be sure to ground the motor and driver to prevent them from being damaged by static electricity.

Except when operating the setting dial, potentiometer or switches on the driver front panel, do not come to close or touch the driver while the driver power is ON. To change the settings of driver acceleration/deceleration time potentiometer, be sure to use an insulated screwdriver.

Maintenance and Cleaning

The CTEL series reservoirs are very simple and reliable reservoirs that require little routine maintenance. However, the following items should be checked periodically to assure continued trouble-free operation of the items listed below.

Always turn off the power before performing maintenance/inspection. Failure to do so may result in electric shock.

Do not conduct the insulation resistance measurement or dielectric strength test with the motor and driver connected. Doing so may cause damage to the product.

The driver uses semiconductor elements, so be extremely careful when handling them. Electrostatic discharge can damage the driver.

1. Disconnect the power from the motor by switching the power off the driver. Do not touch the motor or driver when conducting insulation resistance measurement or dielectric strength test. Accidental contact may result in electric shock. Do not touch the connection terminals on the driver immediately (within 1 minute) after the power is turned off. Residual voltage may cause electric shock.

2. The air relief valve must be cycled with the reservoir pressurised at least once per month. The valve should operate smoothly with normal finger pressure. If the valve requires excessive force to operate or is visibly contaminated, it must be replaced.

3. The condition of the O-ring should be checked for cuts, tears, etc. Any spills on the sealing surface of the reservoir should be wiped clean immediately with a soft, damp cloth and mild soapy water.

4. The pressure regulator should be checked at regular intervals to ensure that it is fully functional.

5. Regularly check the openings of the driver for accumulated dust. Accumulated dust may cause fire.

If further cleaning is required, please follow the safety instruction below.

Make sure the tank has been completely depressurised and discounted from both air line and fluid line.

If cleaning agents are being used on the tank, observe the manufacturer's safety instruction, especially for aggressive and corrosive cleaning agents.

Do not disassemble or modify the motor, gearhead and driver. Doing so may result in electric shock, injury or equipment damage. Should you require inspection or repair of internal parts, please contact SR-TEK.

Always wear proper protective clothing and breathing protection when carrying out cleaning work with chemicals.

During cleaning, ensure that material residues do not react and are not ignited by the tools and cleaning agents used.

The use of highly flammable materials means that there is an increased risk of explosion and fire in the working area.

During inspection:

- Are any of the mounting screws of the motor and gearhead loose?
- Are there any abnormal noises from inside of the motor or gearhead?
- Is there any misalignment between the load shaft and the motor output shaft and gearhead output shaft?
- Are there any scratches, signs of stress or loose driver connections in the cable?
- Are the openings in the driver blocked?
- Are any of the mounting screws or main power input unit of the driver loose?
- Are there any strange smells or appearance within the drive?

If any of the above are detected, contact SR-TEK immediately.

i Agitator Assembly Inspection and Maintenance intervals

Agitator assembly (coupling, shaft and blade)	
Intervals	Actions
Regular	Inspection of shaft coupling for tightness Inspection of sealing O-ring
After 500hrs	Inspection of electric motor
After 2000hrs	Inspection of shaft coupling
After 20,000hrs	Thorough inspection of the whole equipment

For cleaning the tank, use only cleaning agents which **DO NOT** contain the following components: halogenated hydrocarbons (such as trichloroethane, methylene chloride, etc...) acids, and acidic cleaning agents, regenerated solvents (so-called cleaning solvents) or paint removers. These components cause chemical reactions and can result in corrosion damage.

Clean only the mixing components that have been in contact with the fluid (e.g. mixing shaft and blade).

Do not use hard or sharp objects to clean the tank to avoid scratching the surface.

Care must be taken for not bending the mixing mechanism when cleaning the tank. The air must be switched off and discounted from both the tank and electric motor before taking the tank out of operation.

Never immerse the complete tank in solvent or any other cleaning agent as the chemicals will damage the components mounted on the lid and temper their safety function. The tank will no longer be guaranteed.

Do not use cleaning methods which could cause corrosion or which reduce the thickness of the walls (e.g mechanical sanding or sand blasting).

Waste materials produced as a result of cleaning and maintenance work must be properly disposed of, in accordance with the laws and regulations of your country.

Maintenance and repair work may be carried out only on a tank which has been completely depressurised and fully disconnected from both fluid and air lines.

The use of compressed air and regular maintenance will ensure that serious faults will hardly ever occur.

We recommend maintenance after 500 operating hours to guarantee a long service life of the motor.

The maintenance intervals should be shortened for extreme operating conditions. It is advisable for maintenance to be carried out by the manufacturer's service technicians. If you proceed with maintenance yourself, the planetary gears, needle bearings and motor seals must be lubricated with suitable grease (see lubricants). Please note that the lamellae's long service life is not guaranteed when the compressed air is totally dry.



Warning

The motor lamellae contain PTFE. Please comply with the normal health and safety recommendations for these materials. Avoid open flames to prevent any ignition/fumes forming from particles detached from the lamellae. Fumes caused by PTFE particles can cause allergic reactions under certain conditions.



Important

After you have performed any maintenance work on the motor, check that it will work properly. To do so let the motor run for a few seconds in idle mode.

All regulating and safety components must, if they have been supplied by SR-TEK, be replaced only by original SR-TEK parts. List of replacement parts can be found on page 14 and 21. Wearing parts are marked in Bold.

Contact us if you require replacement parts.

Disposal

Materials that remain after cleaning and maintenance must be disposed in compliance with the laws and regulations in place in the country where the equipment is being used. Materials, fluids, cleaning agent improperly disposed endangers the environment and health of beings.

Drawings

2000ML-CTEL

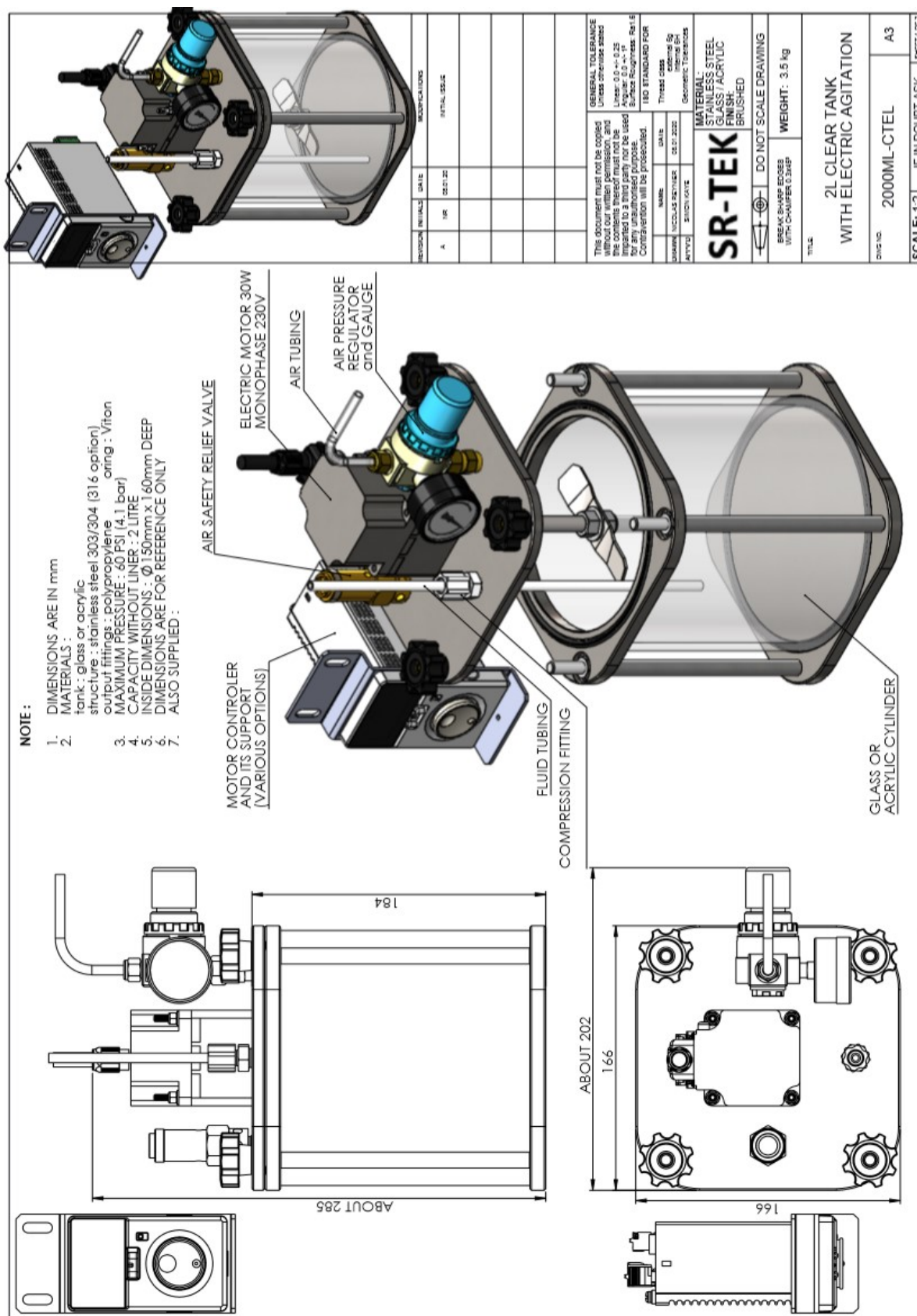

1000CL-CTEL

NOTE:

- DIMENSIONS ARE IN mm
- MATERIALS :
tank : glass or acrylic
structure : stainless steel 303/304 (316 option)
outlet fittings : polypropylene
MAXIMUM PRESSURE : 40 PSI (4 bar)
CAPACITY WITHOUT LINER : 10 LITRE
INSIDE DIMENSIONS : \varnothing 190mm x 360mm DEEP
- DIMENSIONS ARE FOR REFERENCE ONLY
- ALSO SUPPLIED :

REVISION	INITIALS	DATE	MODIFICATIONS
A	SR	10.02.20	1000CL-CTEL

This document must not be copied without our written permission, and the contents must not be reproduced in any form or by any means, electronic or mechanical, for any unauthorized purpose. Contravention will be prosecuted.

DESIGNED BY	NAME	DATE	THRESH CLASS
APPROVED BY	NICHOLAS REVIEWS	10.02.2020	APPROVED BY

SR-TEK
 MATERIAL :
 STAINLESS STEEL
 GLASS / ACRYLIC
 FINISH :
 BRUSHED

DO NOT SCALE DRAWING

BREAK SHARP EDGES WITH CHAMFER 0.3R

WEIGHT : kg

TITLE

10L CLEAR TANK WITH ELECTRIC AGITATION

DWG NO. 1000CL-CTEL A3

SCALE: 1:3 IF IN DOUBT ASK PART 1 OF 2

Warranty

It is the customer's duty to inspect the goods immediately after delivery. In the event of damage or defect, to raise any complaints in writing to SR-TEK. Complaints must be made within a period of 2 working days after receipt of goods. The above also applies to excess or shortage of delivery.

SR-TEK does not accept any liability for damages or loss resulting of misuse, improper installation or operation by the customer or by third parties, normal wear and tear, incorrect or careless usage, the use of unsuitable fluids, substitute materials, defective construction work and unsuitable construction locations or from chemical, electrochemical or electrical influences, unless they are the result of our negligence.

In the event of a warranty claim, we are entitled to choose whether to repair the defect at our own expense or to provide a replacement within a reasonable period of time. If we are not prepared or able to replace or repair, or if a delay occurs for any reasons, the customer is entitled to request a partial or full refund.

The warranty period is six months.

We do not accept liability for any damage other than the delivery item itself.

In the event that liability has not been excluded, our liability to provide compensation is limited to the foreseeable damage; this does not apply if the cause of the damage is the result of wilful action.

In the case of second hand goods, we will accept liability only if these have been overhauled by us and brought to a technical state which approaches the technical state of new goods in accordance with the justified expectation of the customer.

The warranty period on second hand goods is three months.

**If you have any questions,
please contact us for assistance.**

E-mail technical@sr-tek.com