

NOTE :

1. DIMENSIONS ARE IN mm
2. MATERIALS :
 tank : glass or acrylic
 structure : stainless steel 303/304 (316 option)
 output fittings : polypropylene oring : Viton
3. MAXIMUM PRESSURE : 60 PSI (4.1 bar)
4. CAPACITY WITHOUT LINER : 2 LITRE
5. INSIDE DIMENSIONS : \varnothing 150mm x 160mm DEEP
6. DIMENSIONS ARE FOR REFERENCE ONLY
7. ALSO SUPPLIED :

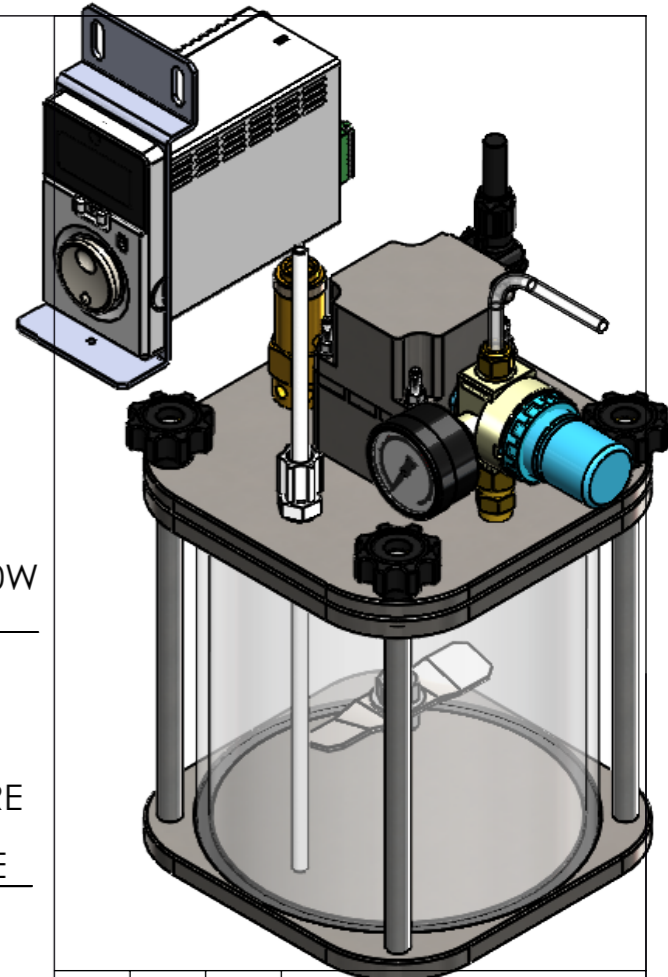
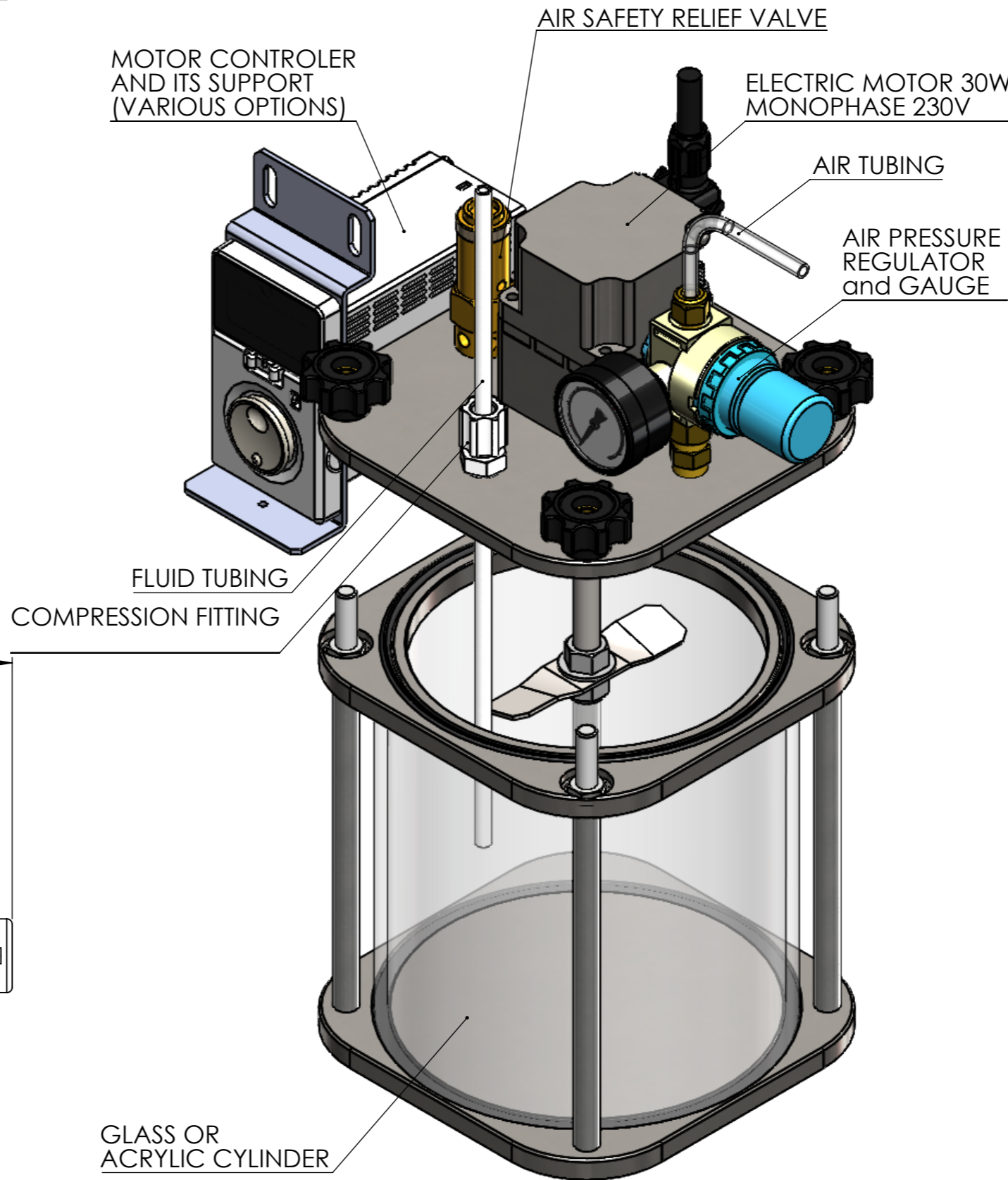

REVISION	INITIALS	DATE	MODIFICATIONS
A	NR	08.01.20	INITIAL ISSUE

This document must not be copied without our written permission, and the contents thereof must not be imparted to a third party nor be used for any unauthorised purpose. Contravention will be prosecuted.

GENERAL TOLERANCE
 Unless otherwise stated
 Linear: 0.0 +/- 0.25
 Angular: 0.0 +/- 1°
 Surface Roughness: Ra1.6

ISO STANDARD FOR
 Thread class
 external 6g
 internal 6H
 Geometric Tolerances

	NAME	DATE
DRAWN	NICOLAS REYNIER	08.01.2020
APPV'D	SIMON KAYE	

SR-TEK **MATERIAL:**
 STAINLESS STEEL
 GLASS / ACRYLIC
FINISH:
 BRUSHED

DO NOT SCALE DRAWING

WEIGHT: 3.5 kg

TITLE:
**2L CLEAR TANK
 WITH ELECTRIC AGITATION**

DWG NO. **2000ML-CTEL** A3

#	PART NUMBER	DESCRIPTION	QTY
1	2008	GLASS OR ACRYLIC CYLINDER 2L	1
2	2009	VITON FLAT SEAL	2
3	2010	BASE PLATE	1
4	518	ROD	4
5	2019-EL	2L LID WITH ELECTRIC MOTOR	1
6	2020	TOP PLATE	1
7	OR-4-148	ORING VITON 148x4	1
8	NM8SS	NUT STAINLESS STEEL M8	4
9	NM8PLSTAR	STAR GRIP M8	4
10	HNIPPLE0.25	NIPPLE NPT 1/4"	1
11	HADAPTERF.25-M.125	1/8 MALE 1/4 FEMALE BSP NIPPLE ADAPTER	1
12	HREGULATORAIR60	AIR PRESSURE REGULATOR 0-60 PSI	1
13	AN-60-G	PRESSURE GAUGE 0-60 PSI	1
14	HADAPTER0.125-6	STRAIGHT ADAPTOR G1/8 x 6mm	1
15	6PE-CL	FLUID TUBING 6mm CLEAR (not supplied)	1
16	FIT-0.25-COMP-6	COMPRESSION ADAPTER 1/4NPT 6mm	1
17	6PE-WH-0.5L	CLEAR TUBING DIAM6	1
18	60-SV	SAFETY VALVE 0.25 60PSI	1
19	1026	ELECTRIC MOTOR 30W	1
20	1027	ELECTRIC CABLE CONTROLER-MOTOR	1
21	OR-2-16	O-RING 16x2.0 VITON	1
22	W4.5SSBONDED	BONDED SEAL 4.5	4
23	91292A269	BOLT M4x0.8 70L STAINLESS CAP HEAD	4
24	93237A106	BELLEVILLE SPRING LOCK WASHER M4	4
25	93625A150	NUT M4 STAINLESS NYLON LOCK	4
26	HCOUPLING1010	SHAFT COUPLER 10 10	1
27	1021	MIXER SHAFT	1
28	1022-P11	MIXING BLADE	1
29	NM10SSFLANGE	FLANGE NUT M10	1
30	NM10SSLOCK	LOCKING NUT M10	1
31	1028	MOTOR CONTROLER SUPPORT	1
32	1029	MOTOR CONTROLER	1

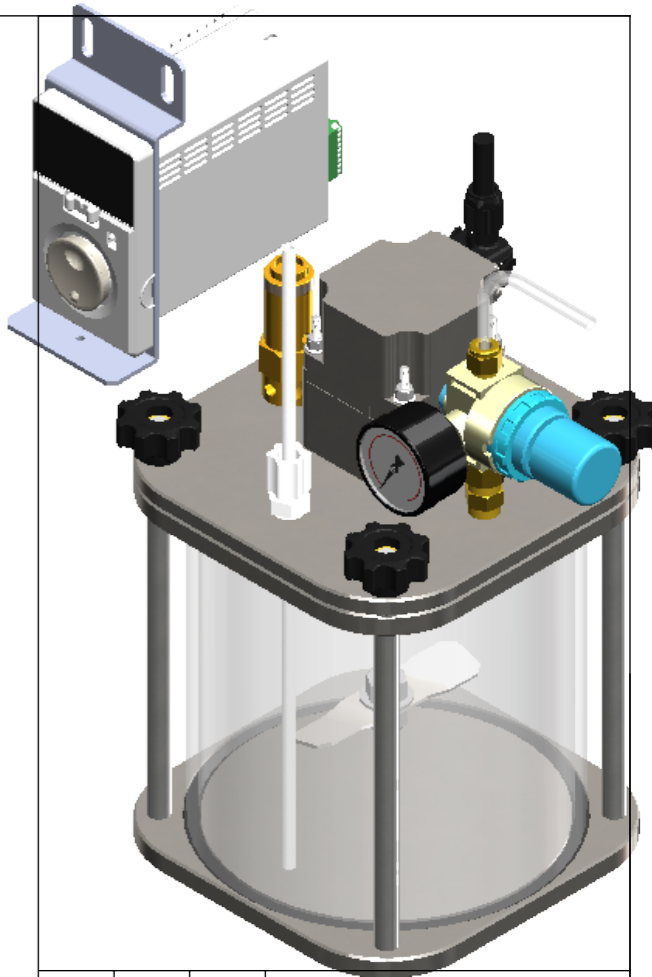
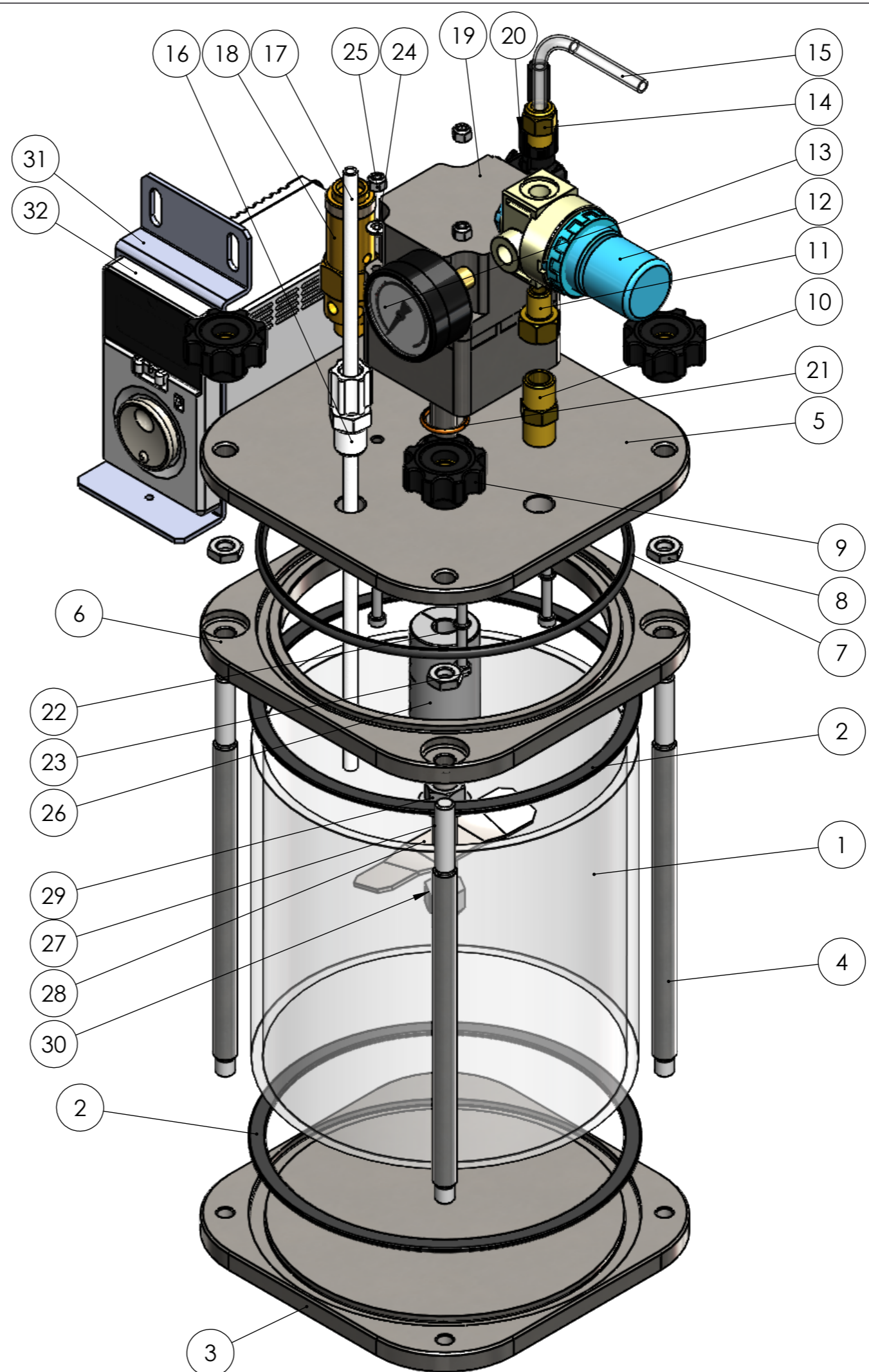

REVISION	INITIALS	DATE	MODIFICATIONS
A	NR	08.01.20	INITIAL ISSUE

This document must not be copied without our written permission, and the contents thereof must not be imparted to a third party nor be used for any unauthorised purpose. Contravention will be prosecuted.		GENERAL TOLERANCE Unless otherwise stated Linear: 0.0 +/- 0.25 Angular: 0.0 +/- 1° Surface Roughness: Ra1.6
ISO STANDARD FOR Thread class external 6g internal 6H Geometric Tolerances		
DRAWN	NICOLAS REYNIER	08.01.2020
APP'VD	SIMON KAYE	

SR-TEK MATERIAL: STAINLESS STEEL
GLASS / ACRYLIC
FINISH: BRUSHED

DO NOT SCALE DRAWING

BREAK SHARP EDGES WITH CHAMFER 0.3x45° WEIGHT: 3.5 kg

TITLE:
2L CLEAR TANK WITH ELECTRIC AGITATION

DWG NO. **2000ML-CTEL** A3

SCALE: 1:2 IF IN DOUBT ASK SHEET 2 OF 2