

COUPE A-A

- NOTE :**
1. DIMENSIONS ARE IN mm
 2. MATERIALS :
 tank and cover : stainless steel 303/304 (316 OPTION)
 dip tube :
 output fittings : polypropylene
 oring : Viton
 3. MAXIMUM PRESSURE : 100 PSI (6.9 bar)
 4. CAPACITY WITHOUT LINER : 5 LITRES
 5. INSIDE DIMENSIONS : \varnothing 150mm x 315mm DEEP
 6. DRY WEIGHT :
 7. DIMENSIONS ARE FOR REFERENCE ONLY
 8. ALSO SUPPLIED :

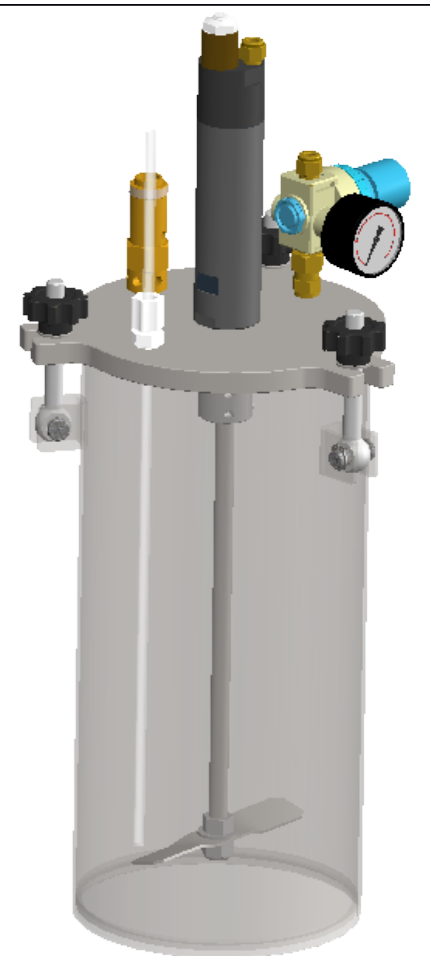
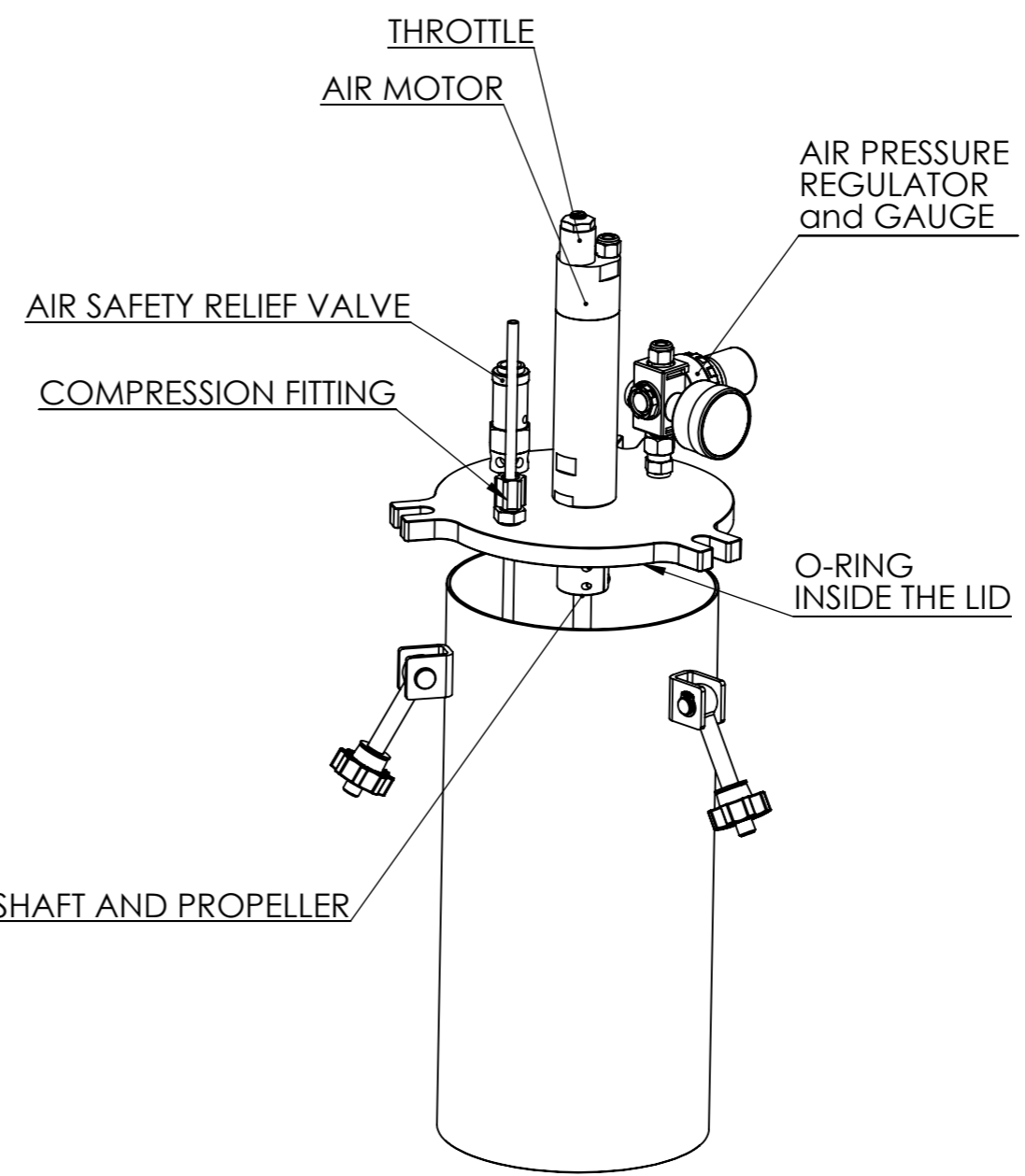
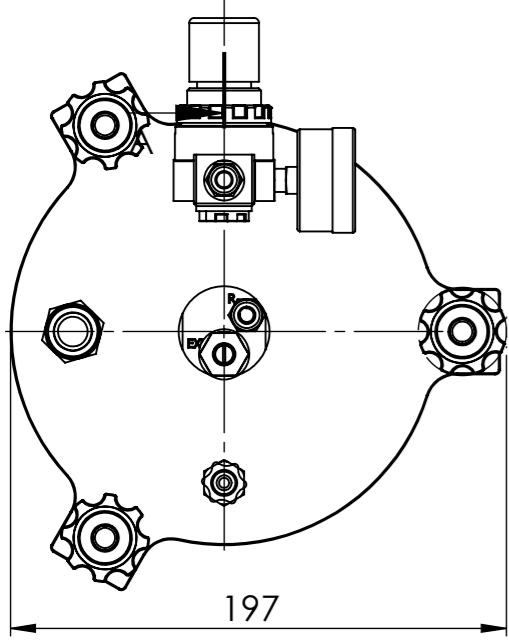

REVISION	INITIALS	DATE	MODIFICATIONS
A	NR	27.04.15	INITIAL ISSUE
B	NR	16.04.20	UPDATE OF VARIOUS ELEMENTS

This document must not be copied without our written permission, and the contents thereof must not be imparted to a third party nor be used for any unauthorised purpose. Contravention will be prosecuted.		GENERAL TOLERANCE Unless otherwise stated Linear: 0.0 +/- 0.25 Angular: 0.0 +/- 1° Surface Roughness: Ra1.6						
<table border="1"> <thead> <tr> <th>NAME</th> <th>DATE</th> </tr> </thead> <tbody> <tr> <td>DRAWN NICOLAS REYNIER</td> <td>27.04.2015</td> </tr> <tr> <td>APPV'D SIMON KAYE</td> <td> </td> </tr> </tbody> </table>		NAME	DATE	DRAWN NICOLAS REYNIER	27.04.2015	APPV'D SIMON KAYE		ISO STANDARD FOR Thread class external 6g internal 6H Geometric Tolerances
NAME	DATE							
DRAWN NICOLAS REYNIER	27.04.2015							
APPV'D SIMON KAYE								

SR-TEK MATERIAL: STAINLESS STEEL
 FINISH: BRUSHED

DO NOT SCALE DRAWING

BREAK SHARP EDGES WITH CHAMFER 0.3x45° WEIGHT: g

TITLE:
5L RESERVOIR ASSY WITH AIR MOTOR

DWG NO. **5000ML-STAG Revision B** A3

SCALE: 1:3 IF IN DOUBT ASK SHEET 1 OF 2

#	PART NUMBER	DESCRIPTION	QTY
1	5011B	5L RESERVOIR BODY	1
2	5010L-AG	5L RESERVOIR LID	1
3	OR-4.5-140	O-RING 140mm ID x 4.5mm	1
4	BM10x75SSSWING	SWING BOLT M10	3
5	1015	DOWEL PIN	3
6	HCIRCLIPXT10	CIRCLIP EXTERNAL D10	3
7	WM10-19SS	WASHER M10	3
8	NM10PLSTAR	EIGHT LOBED KNOB M10 PLASTIC BRASS	3
9	HADAPTERF.25-M.125	1/8 MALE 1/4 FEMALE BSP NIPPLE ADAPTER	1
10	HNIPPLE0.25	NIPPLE NPT 1/4"	1
11	HREGULATORAIR100	PRESSURE REGULATOR 0-100 PSI	1
12	AN-100-G	PRESSURE GAUGE 0-100PSI	1
13	HADAPTER0.125-6	STRAIGHT ADAPTOR G1/8 x 6mm	2
14	100-SV	SAFETY VALVE 0.25 100 PSI	1
15	FIT-0.25-COMP-6	COMPRESSION ADAPTER 1/4NPT 6mm	1
16	6PE-CL-5L	FLUID TUBING 6mm CLEAR (not supplied)	1
17	1017-AM	AIR MOTOR 250W	1
18	OR-2-26	O-RING 26mm ID x 2mm	1
19	5021	5L AIR MIXER SHAFT	1
20	5L-12510-SINGLE	PROPELLER	1
21	HCOUPLING1010	SHAFT COUPLER 10 10	1
22	NM10SSFLANGE	FLANGE NUT M10	1
23	NM10SSLOCK	LOCKING NUT M10	1
24	HAIRTH	THROTTLE FOR AIR MOTOR	1

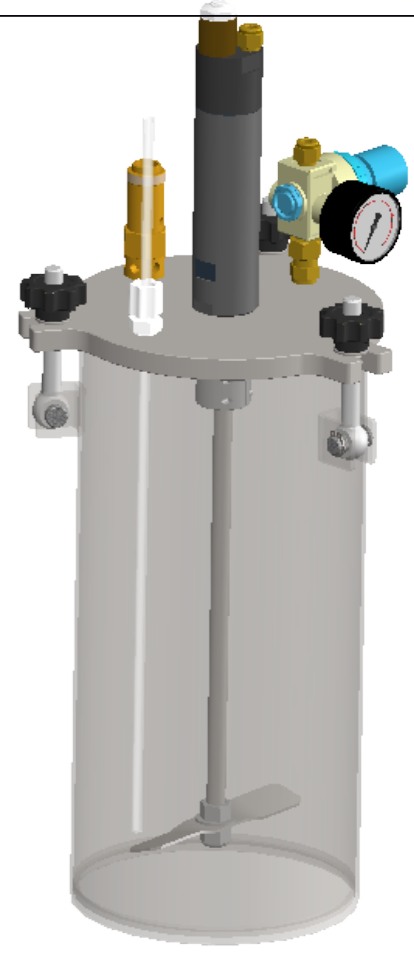
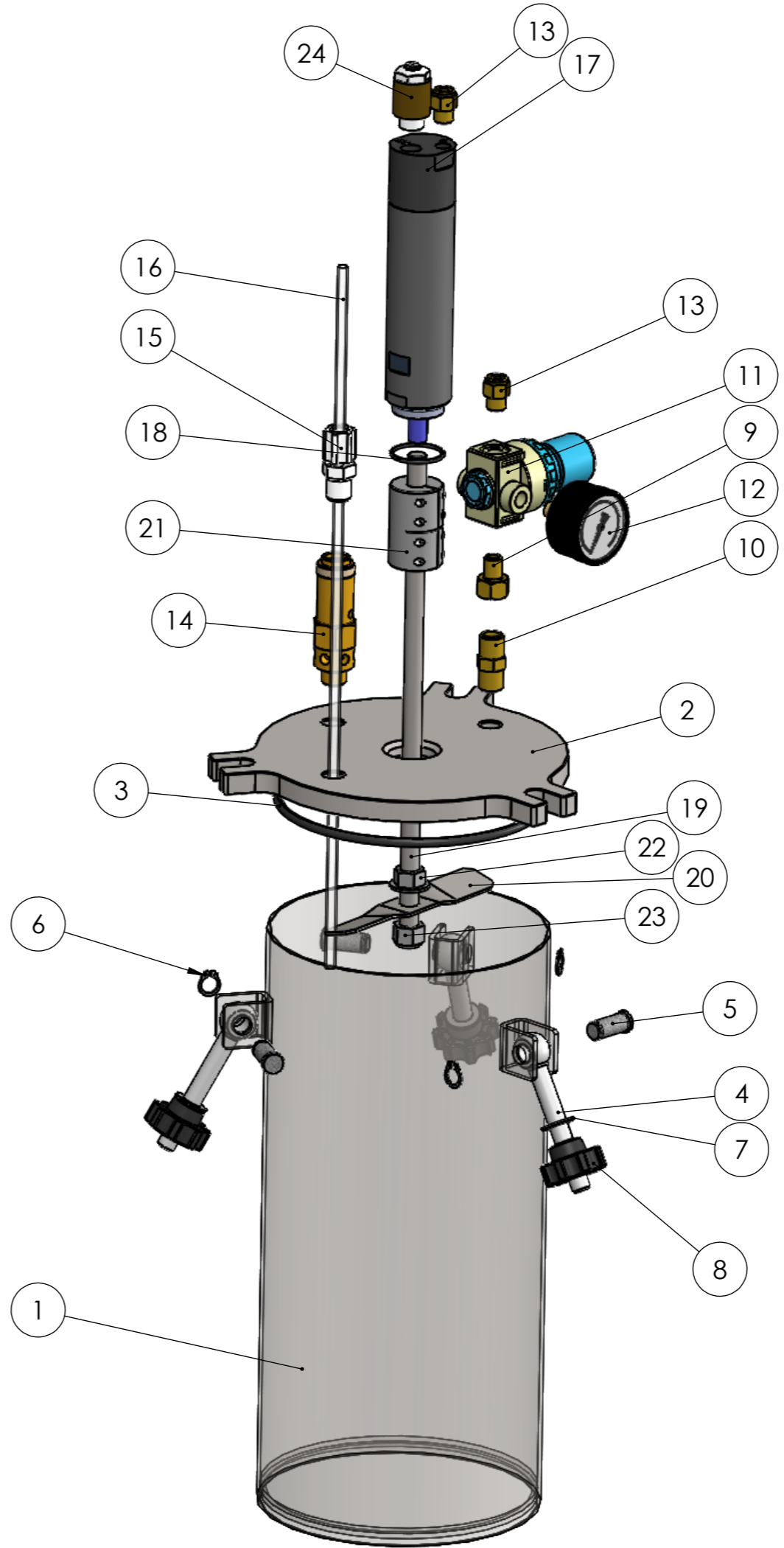

REVISION	INITIALS	DATE	MODIFICATIONS
A	NR	27.04.15	INITIAL ISSUE
B	NR	16.04.20	UPDATE OF VARIOUS ELEMENTS

This document must not be copied without our written permission, and the contents thereof must not be imparted to a third party nor be used for any unauthorised purpose. Contravention will be prosecuted.

GENERAL TOLERANCE
Unless otherwise stated
Linear: 0.0 +/- 0.25
Angular: 0.0 +/- 1°
Surface Roughness: Ra1.6

ISO STANDARD FOR
Thread class
external 6g
internal 6H
Geometric Tolerances

NAME	DATE
DRAWN NICOLAS REYNIER	27.04.2015
APPV'D SIMON KAYE	

SR-TEK MATERIAL: STAINLESS STEEL
FINISH: BRUSHED

DO NOT SCALE DRAWING

BREAK SHARP EDGES WITH CHAMFER 0.3x45° WEIGHT: g

TITLE:
5L RESERVOIR ASSEMBLY WITH AIR MOTOR

DWG NO. **5000ML-STAG Revision B** A3

SCALE: 1:3 IF IN DOUBT ASK SHEET 2 OF 2