

NOTE :

1. DIMENSIONS ARE IN mm
2. MATERIALS :
 tank : glass or acrylic
 structure : stainless steel 303/304 (316 option)
 output fittings : polypropylene oring : Viton
3. MAXIMUM PRESSURE : 60 PSI (4.1 bar)
4. CAPACITY WITHOUT LINER : 2 LITRE
5. INSIDE DIMENSIONS : \varnothing 150mm x 160mm DEEP
6. DIMENSIONS ARE FOR REFERENCE ONLY
7. ALSO SUPPLIED :

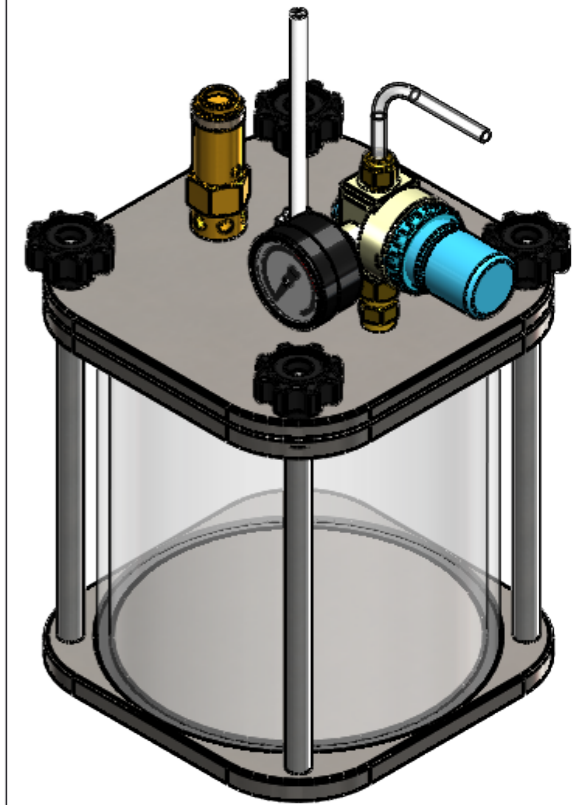
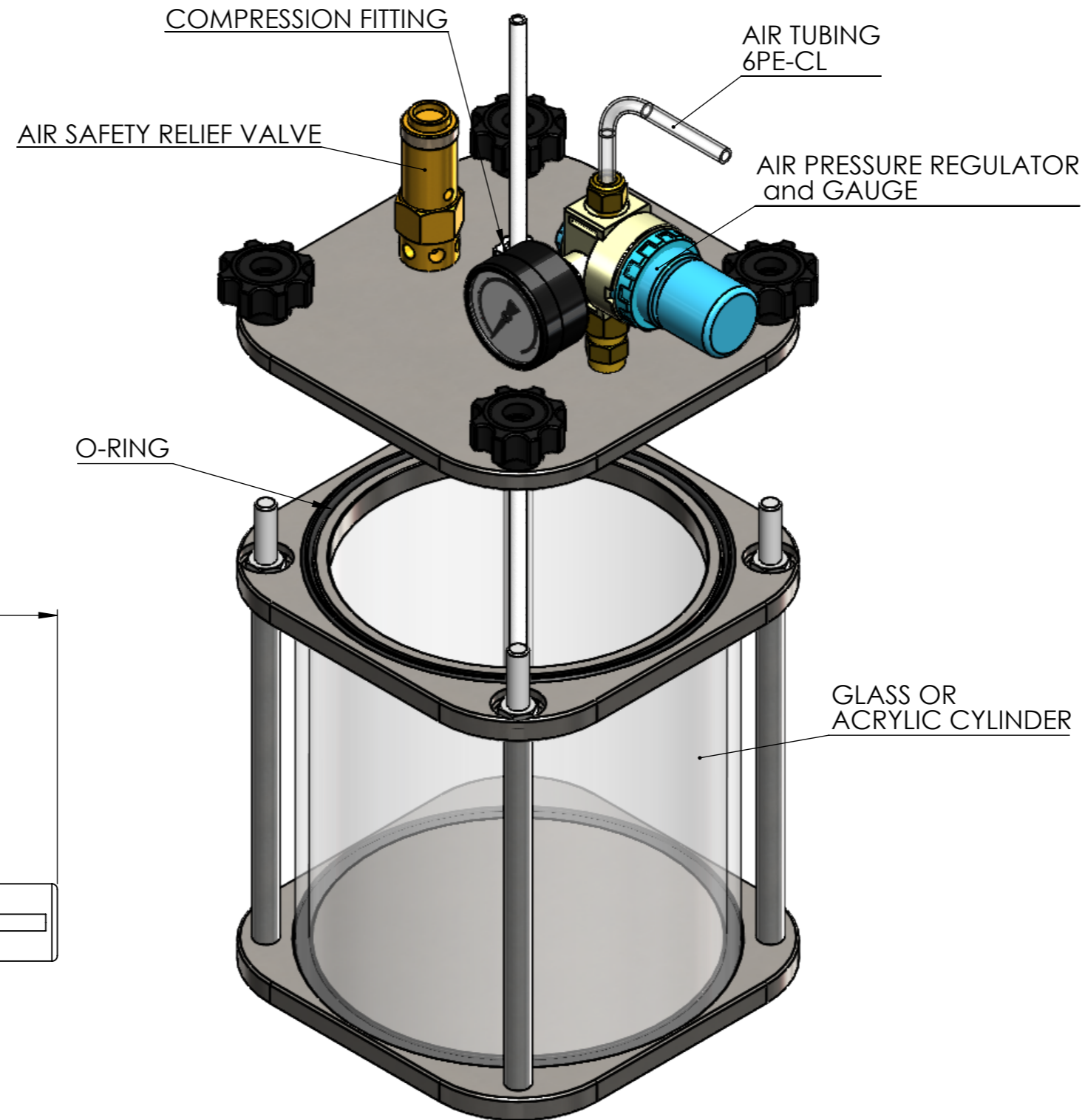

REVISION	INITIALS	DATE	MODIFICATIONS
A	NR	30.07.16	INITIAL ISSUE
B	NR	07.11.17	THINNER AND LIGHTER
C	NR	26.05.19	UPDATE OF VARIOUS MODELS TO FIT REALITY

This document must not be copied without our written permission, and the contents thereof must not be imparted to a third party nor be used for any unauthorised purpose. Contravention will be prosecuted.		GENERAL TOLERANCE Unless otherwise stated Linear: 0.0 +/- 0.25 Angular: 0.0 +/- 1° Surface Roughness: Ra1.6
		ISO STANDARD FOR Thread class external 6g internal 6H Geometric Tolerances
DRAWN	NICOLAS REYNIER	30.07.2016
APPV'D	SIMON KAYE	

SR-TEK MATERIAL: STAINLESS STEEL
 GLASS / ACRYLIC
 FINISH: BRUSHED

DO NOT SCALE DRAWING
 BREAK SHARP EDGES WITH CHAMFER 0.3x45° **WEIGHT: 2.6 kg**

TITLE:
2L CLEAR TANK

DWG NO. **2000ML-CT** **Revision C** **A3**

#	PART NUMBER	DESCRIPTION	QTY
1	2008	GLASS OR ACRYLIC CYLINDER 2L	1
2	2009	VITON FLAT SEAL	2
3	2010	BASE PLATE	1
4	518	ROD	4
5	2019	LID	1
6	2020	TOP PLATE	1
7	OR-4-148	ORING VITON 148x4	1
8	NM8SS	NUT STAINLESS STEEL M8	4
9	NM8PLSTAR	STAR GRIP NUT M8	4
10	HNIPPLE0.25	NIPPLE NPT 1/4"	1
11	HADAPTERF.25-M.125	1/8 MALE 1/4 FEMALE BSP NIPPLE ADAPTER	1
12	HREGULATORAIR60	AIR PRESSURE REGULATOR 0-60 PSI	1
13	AN-60-G	PRESSURE GAUGE 0-60 PSI	1
14	HADAPTER0.125-6	STRAIGHT ADAPTOR G1/8 x 6mm	1
15	6PE-CL	FLUID TUBING 6mm CLEAR	1
16	FIT-0.25-COMP-6	COMPRESSION ADAPTER 1/4NPT 6mm	1
17	6PE-WH-0.5L	CLEAR TUBING DIAM6	1
18	60-SV	SAFETY VALVE 0.25 60PSI	1

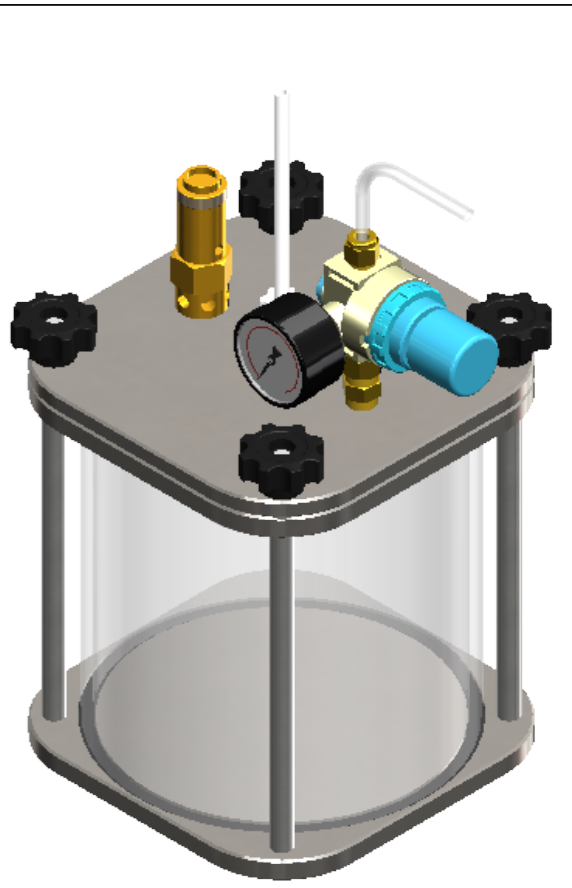
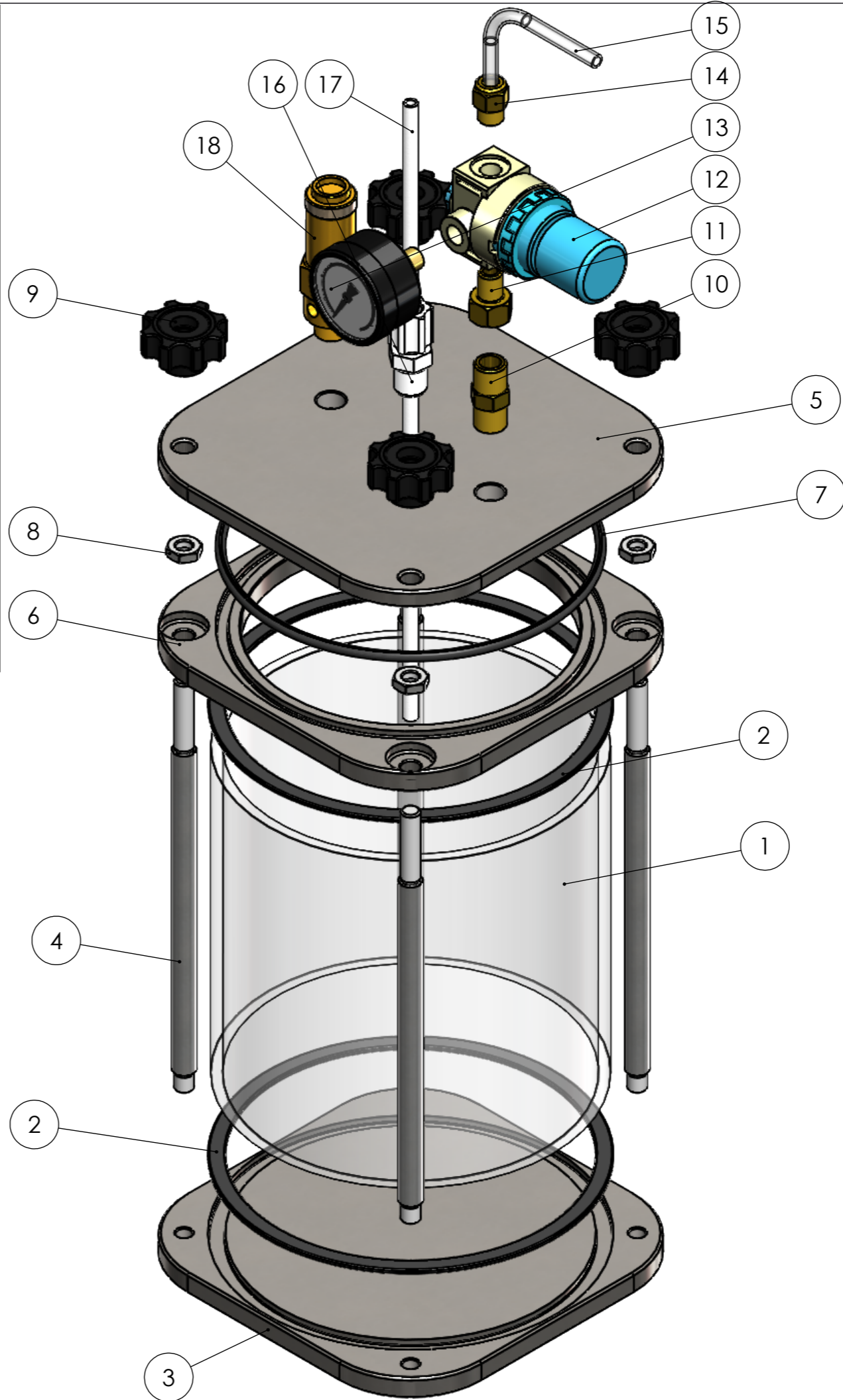
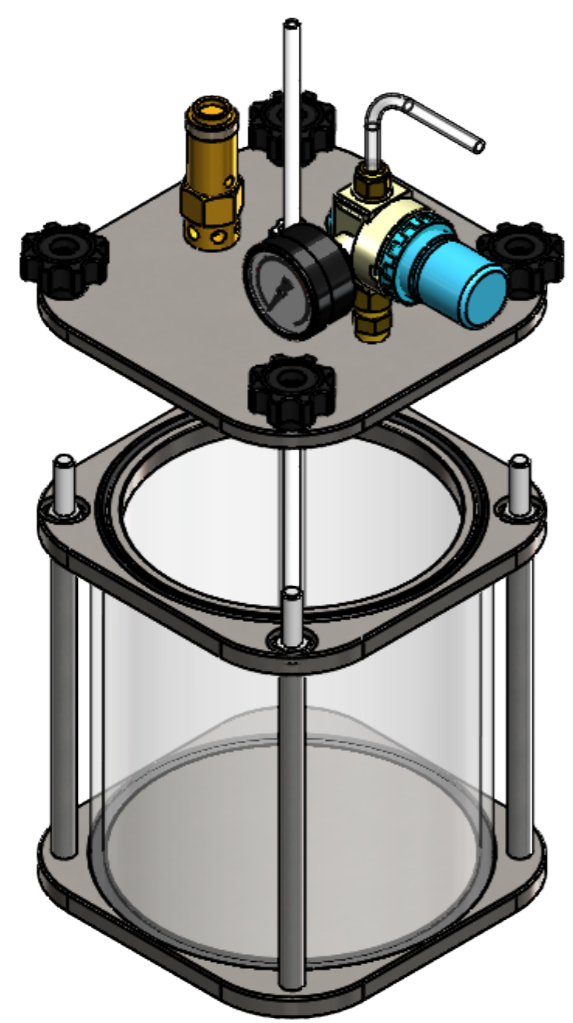

REVISION	INITIALS	DATE	MODIFICATIONS
A	NR	30.07.16	INITIAL ISSUE
B	NR	07.11.17	THINNER AND LIGHTER
C	NR	26.05.19	UPDATE OF VARIOUS MODELS TO FIT REALITY

This document must not be copied without our written permission, and the contents thereof must not be imparted to a third party nor be used for any unauthorised purpose. Contravention will be prosecuted.

GENERAL TOLERANCE
Unless otherwise stated
Linear: 0.0 +/- 0.25
Angular: 0.0 +/- 1°
Surface Roughness: Ra1.6

ISO STANDARD FOR
Thread class
external 6g
internal 6H
Geometric Tolerances

	NAME	DATE
DRAWN	NICOLAS REYNIER	30.07.2016
APPV'D	SIMON KAYE	

SR-TEK MATERIAL: STAINLESS STEEL
GLASS / ACRYLIC
FINISH: BRUSHED

DO NOT SCALE DRAWING

BREAK SHARP EDGES WITH CHAMFER 0.3x45° WEIGHT: 2.6 kg

TITLE:
2L CLEAR TANK

DWG NO. **2000ML-CT** Revision C A3

SCALE: 1:2 IF IN DOUBT ASK SHEET 2 OF 2